

Furniture for workspaces, hospitality,
public spaces and retail

Mobles114

Bringing comfort
to collective spaces
since 1973

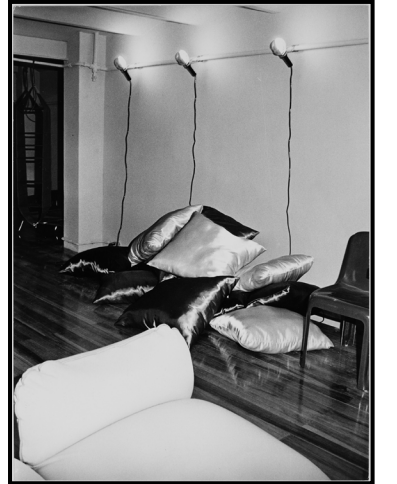
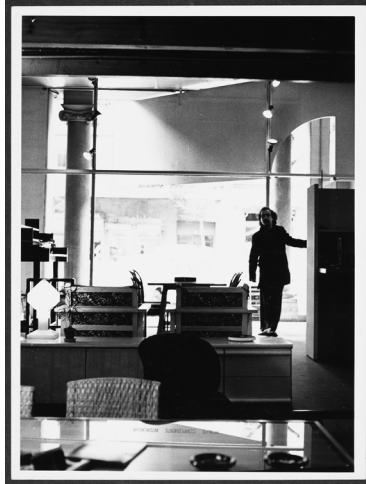

The most sustainable design is one that lasts forever

Mobles 114 is a Barcelona-based company founded in 1973. It offers a collection of furniture and objects designed with people in mind. The furniture is intended for living spaces, regardless of trends, consciously designed and made with quality and durable materials, whether for domestic, work, or collective environments.

For over 50 years, Mobles 114 has been offering furniture and objects, some iconic, to accompany people throughout their lives with the intention that these pieces become part of their space silently and pass from generation to generation.



Our history



Mobles 114 was founded in Barcelona in 1973 by designers JM Massana, JM Tremoleda, and Mariano Ferrer. Its first headquarters were located at Carrer d'Enric Granados 114, and this is the origin of the name: a location in the heart of a city that was beginning to experience social and cultural changes that had started in Europe in 1968. The company was initially established as an interior design studio and store, offering a selection of products manufactured by local companies and other contemporary designs imported from European countries, while also initiating their own designs and productions.

Massana and Tremoleda not only design but also curate a collection of furniture and objects where tradition and modernity converge. This collection is influenced by the proposals promoted by the architects of the GATCPAC

during the 1930s, who participated in European architectural rationalism, with figures such as Le Corbusier, Ludwig Mies van der Rohe, or Walter Gropius, among others. However, these influences did not make them forget their Mediterranean roots. Tradition is represented in the recovery and reissue of classics from Catalan design, while modernity is evident in their own proposals and in the choice of designers or authors who will sign for the Mobles 114 catalog.

Over these 50 years, furniture and objects designed by Álvaro Siza, André Ricard, Antoni Arola, Carlos Riart, Enzo Mari, Eugeni Quitllet, Gabriel Mora, Gabriel Ordeig, Germán Rodríguez Arias, Isamu Noguchi, Isidre Ferrer, Mariano Ferrer, Javier Mariscal, Joan Gaspar, Jorge



Pensi, José Antonio Coderch, Josep Maria Jujol, Josep Torres Clavé, Lagranja, Lluís Pau, Lluís Porqueras, Martín Azúa, Massana-Tremoleda, Josep Mora, Miguel Milá, Montse Padrós, Oscar Tusquets, Pete Sans, Rafael Marquina, and Santiago Roqueta have participated in our catalog.

Mobles 114 has received several awards, but we are convinced that the best recognition is not awarded by a jury, but by the people who live with our furniture. For decades, this recognition has made it possible for the timelessness of furniture and objects to endure through generations.

This spirit of permanence, of enduring forever, of accompaniment, is what has guided us as a company to act with coherence and understatement, maintaining a profound respect for tradition and a sincere admiration for modernity.

“I am exalted by the new, enamored of the old.”
– J.V. Foix. Sol, i de dol (1947).

Editions, designers and authors

Mobles 114 undertakes a commitment to creating furniture designed by authors who prioritize simplicity and avoid the unnecessary to obtain pieces that endure over time.

Over these five decades, we have developed a catalog of products in collaboration with designers and authors from various fields who contribute their knowledge to find the best solutions. This teamwork strengthens both the product and the designer and the company.

Such editing process, initiated by the founders JM Massana and JM Tremoleda, turns into a catalog with its own personality which remains relevant and always takes care of the forms, materials and uses to ensure they are useful, comfortable, discreet and durable.



Meet the designers



Antoni Arola
Tarragona, 1960

He combines design, artistic experimentation and research on light. He has developed his work in the fields of lighting, furniture, interior projects and installations. With a remarkable perspective, his works are the result of continuous pursuit of beauty, with a highly personal commitment to research where light is the focus.

He has participated in solo and group exhibitions in Barcelona, New York, Milan, London, Tokyo, Mexico, among others. He has received the Delta Silver Award in 1999, 2001, and 2012, the National Design Award in 2003, and the I-Plus Award in 2009 (best lighting), among many others.

Taiga Coatstand



Martín Azúa
Vitòria, 1965

A Basque designer, he carries out his work in the city of Barcelona, where he combines teaching, product design and research with craftsmanship.

His work has a strong poetic component. The result is a coherent discourse, both in the most conceptual proposals and in everyday use objects. Very interested in the craftsmanship

and tradition of “know-how,” he has worked closely with many artisans to create objects of undeniable beauty where design and tradition are integrated with forcefulness.

Among his most well-known projects is “Casa Básica,” which has been part of the permanent collection of the MOMA in New York since 2007. He has received the City of Barcelona Award in 2000, the Delta Silver Award in 2007, the FAD Architecture / Ephemeral Award in 2008, the Design Plus Award in 2009, the Interiorismo Plus Award in 2009, and the AD Award for best designer of the year in 2010.

Luco Stool, Rambla Collection, Om Armchair



Joan Gaspar
Barcelona, 1966

Industrial designer, he began his career alongside Lluís Porqueras in lighting design. Throughout his career, Joan Gaspar has primarily designed lighting elements, furniture and pieces in other disciplines. He stands out for his attention to detail and highly ingenious solutions. His passion for design and a profound knowledge of materials and production techniques are essential elements of his designs.

In addition to design, he combines his work with product management and direction at the lighting company Marset.

Throughout his career, he has received several Delta awards, among which stand out those

awarded for the Atlas light in 2001 and for the Neón de Luz in 2005.

Hulot Coatstand



Josep Maria Jujol
1879-1949

He was an architect, draftsman, designer and Catalan modernist painter.

As a collaborator of Antoni Gaudí, he participated in his work with his own personality. The architect Gaudí entrusted him with the projection of part of his works with absolute creative freedom.

Starting from 1904, he collaborated with Gaudí in the design of the main facade of Casa Batlló or in the wrought iron railings and some of the plaster ceilings of Casa Milà (popularly known as ‘La Pedrera’), among other works.

Among Jujol’s architectural works, we highlight the Metropol Theater (1908) in Tarragona or the remodelling of Casa Bofarull (1913 - 1931) in Els Pallaresos, Tarragona.

From his collaboration with Gaudí, we highlight Casa Batlló (1904 - 1906), Casa Milà (La Pedrera) (1906 - 1910) and Park Güell (1900 - 1914), all of them in Barcelona.

Jujol 1920 Sidetable



Lagranja design
Gerard Sanmartí, Barcelona, 1974
Gabriele Schiavon, Pàdua, 1973

Lagranja Design is a design studio founded in 2002 by Gerard Sanmartí and Gabriele Schiavon in the city of Barcelona. They have become established as a team of professionals from various fields, such as product design, graphic design or interior design, with an identity that serves as the common thread for the different projects they have carried out.

Their interior designs are recognized for their strong personality. The products they design feature clear and sober lines. But above all, behind each proposal lies a research effort on form which balances playfulness and rigor.

Forc Coatstand



Javier Mariscal
València, 1950

Mariscal is an image creator across all media and disciplines, who, from an innocent perspective, always dares to provoke us.

His work intertwines the different disciplines in which he works; that’s why the furniture designed by Mariscal always has a surprising visual impact where a reading

between the graphic and the object stands out.

He has been awarded the National Design Award 1999 and the National Culture Award 2011, as well as several selections and awards such as Laus ADG-FAD and Delta ADI-FAD.

Green Chair



JM Massana
Barcelona, 1947
JM Tremoleda
Barcelona, 1946

Pioneers of industrial design in Barcelona, both graduated from the Escola Massana in the first class of this discipline in 1969. In 1973, along with Mariano Ferrer, they founded Mobles 114, a furniture store and interior design studio where their initial designs and productions emerged.

Beyond their undeniable role as editors at Mobles 114, Massana - Tremoleda designed many of the furniture pieces in the catalog. Their work stands out for the emphasis placed on the functionality of the object and the departure from formalist exercises. Many of their designs continue to be part of Mobles 114’s catalog due to their timeless quality demonstrated by their long-standing presence in the market; these are pieces of furniture that, far from fleeting trends, maintain relevance and validity.

The work of Massana - Tremoleda as editors and

entrepreneurs of the Mobles 114 brand earned recognition from the jury of the 2001 National Award “for the perseverance and coherence demonstrated over the years, reflected in the quality of their products”.

Tria Shelving System, Pey Table System, Gràcia Collection, Danesa, Mirac, Bambú, Platea, Riga Collection, Oxi Bistrot.



Miguel Milá Sagnier
Barcelona, 1931

He began his career in the late 1950s and he considers himself a preindustrial designer.

His designs are the result of meticulous and seemingly simple work that has led many of his products to be recognized as icons of industrial design in our country. Milá removes all the excess from a product to focus on the essence, on what is fundamental.

He has been awarded the first edition of the National Design Award in 1987 and the Compasso D’Oro in 2008 in recognition of his career..

MMS 1963, Tombal



Montse Padrós
Badalona 1952

She is an industrial designer and interior designer trained at the Elisava Design School and the School of Arts and Crafts of Barcelona. After working for the architecture studio MBM Arquitectes (Martorell-Bohigas-Mackay), Joaquim Prats’ studio and for AD Associate Designers, she has been working freelance since 1991.

Montse Padrós’s designs are the result of observing how materials and manufacturing techniques relate to space. She also has a knack for achieving new forms for everyday uses. The Ona coat rack, designed in collaboration with Carlos Riart, is an example of this.

She received the Delta d’Or ADI FAD Award in 1992

Ona Coatstand



Lluís Pau
Castellfollit de la Roca, 1950

Industrial and interior designer, he joined the architecture studio MBM (Martorell-Bohigas-Mackay) in 1973. Starting in 1978, he took charge of the IDP studio, where he developed projects for exhibitions, museums, temporary spaces, libraries, stage sets and signposting, among others. Lluís Pau’s designs stand out

for their minimalism in form. They are elemental designs that rely on the use of materials and structure to shape form and function. In essence, simplicity and utility.

Some of his designs belong to the permanent collection of the Barcelona Design Museum.

Nuta Stool



Eugeni Quitllet,
Eivissa, 1972

He studied in Barcelona and began his international career alongside Philippe Starck. In 2011, he returned to Barcelona and founded his own studio.

Eugeni Quitllet is endowed with a creative capacity that always surprises and a brilliant expressiveness. He has been described as a renovator, tireless seeker and tech enthusiast. For Quitllet, design revolves around thinking about what has not yet been created, whether it's an object or an idea, but always projecting into the future.

Tube Collection



Carles Riart
Barcelona, 1944

Carles Riart is an unclassifiable designer. He is highly interested in the constructive knowledge of furniture. After his training at the Eina School, he worked closely with a cabinetmaking workshop with which he developed a significant part of his work. Carles Riart could be defined more as a "furniture maker" rather

than a designer in the more usual sense of the word.

He has been awarded the Furniture Contemporary Resources Council Prize (New York, 1983), the European Top-Ten Award (Cologne, 1994), the Grand Prix de la Presse Internationale (Paris, 1994), and the National Design Award in 2011, in addition to numerous Delta awards, among which the Delta d'Or for the "ONA" coat rack stands out, designed jointly with Montse Padrós in 1992.

Ona Coatstand



André Ricard
Barcelona, 1929

Internationally renowned designer, he has designed packaging, household utensils, lighting fixtures, household appliances and furniture pieces that have become part of the daily domestic landscape. Among his most famous works are the design of the Copenhagen ashtray, edited by Mobles 114, and the Olympic torch for the 1992 Barcelona Olympic Games.

André Ricard has been recognized with the National Design Award of Spain, the *Creu de Sant Jordi* of the Generalitat de Catalunya, the Olympic Order of the International Olympic Committee, the Gold Medal for Artistic Merit of the city of Barcelona, and he is also a Chevalier des Arts et des Lettres and a Chevalier de la Légion d'Honneur in France.

Copenhaguen 1966, Tong 1964



Germán Rodríguez Arias
Barcelona, 1902 - 1987

Catalan architect and designer, he was instrumental, along with Josep Lluís Sert, Josep Torres Clavé, Sixte Illescas and Ricardo de Churruga, among others, in introducing architectural rationalism to Catalonia. He was a founding member of the GATCPAC.

With Cristián Aguadé and Claudi Tarragó, he founded the company Muebles Sur, which became one of the most important furniture factories in Chile.

In 1957, he returned to his native country and settled in Ibiza, where he was reunited with his colleagues Sert, Prats, and Illescas. In Ibiza, he worked as a municipal architect and balanced this activity with his private architectural practice, mainly focusing on hotels and residences. His own house in Portinatx stands out among his projects.

Catalana 1942



Álvaro Siza Vieira
Matosinhos, 1933

Álvaro Siza was born in Matosinhos, Portugal. An architect of international renown initially recognized for his early works in Portugal, he is known for the elegance and respectful integration of architecture with the landscape. Examples of this integration include the Marés swimming pools in Leça de Palmeira or the Da Boa Nova restaurant.

His architecture stands out for its minimalism and efficiency, devoid of artifice, conveying a sense of serenity. Siza has left his mark in many countries, always maintaining the ability to evoke emotions through

his work. He has received numerous architecture awards, notably including the Mies Van der Rohe Award in 1988 and the Pritzker Prize in 1992.

Fil 1991



Josep Torres Clavé
Barcelona, 1906 - Els Omellons,
1939

Architect, urban planner, designer and educator. A founding member of GATCPAC (Group of Catalan Artists and Technicians for the Progress of Contemporary Architecture) and a prominent advocate for rationalist architecture in our country.

He began his career as an architect alongside Josep Lluís Sert and Antoni Bonet Castellana. He directed the magazine AC (A.C. Documents of Contemporary Activity), through which he introduced artists such as Le Corbusier, Walter Gropius, Mies van der Rohe, Erich Mendelsohn, Van Doesburg, Neutra, Lubetkin, Joan Miró or Pablo Picasso.

In his short career as a designer, he left a brief but significant imprint. He designed chairs, tables, and lamps among other pieces of furniture, he designed chairs, tables and lamps. The one that stands out the most is the Torres Clavé armchair, reissued by Mobles 114.

Josep Torres Clavé died at the age of 33 during the Spanish Civil War.

Torres Clavé 1934

We are committed to...

Creation

Creating furniture designed by authors who seek simplicity and avoid the unnecessary to obtain furniture or objects that endure over time.

Sustainability

Fostering 100% local production and a continuous improvement process of products and production processes with the aim of reducing our environmental impact.

Production

Maintaining a close relationship with a local network of suppliers from the province of Barcelona since our beginnings.

People

Promoting the teamwork of all the people involved in the company; whether it's the people who are part of it or our suppliers and customers who participate in the sale of quality products for people who value them.

Memory

Recovering furniture and objects that we believe are part of the material heritage of our culture. We do this through the search for furniture that is not on the market and that we incorporate into our Classics collection.



Classic Collection

With the Classic collection, we aim to rescue furniture and objects from oblivion or museum collections because we believe they are part of the material heritage of our culture. We do this through the search for furniture that is not on the market and that we incorporate because, due to their conception and design, they retain their relevance intact.



Torres Clavé 1934

Josep Torres Clavé
Barcelona 1906 - Els Omellons 1939



01

Torres Clavé armchair was exhibited at the International Exhibition in Paris in 1937 along with other world-renowned artworks such as Picasso's Guernica.

The architect Josep Torres Clavé designed this armchair in 1934 to furnish the Pavilion of the Spanish Republic at the 1937 International Exhibition in Paris, next to works such as Guernica by Pablo Picasso and others by Alexander Calder or Joan Miró.

The Torres Clavé armchair is inspired by the traditional chair from Ibiza.

It has formed part of the Permanent Collection at Barcelona's Design Museum since 1994. It is produced using traditional processes and is one of the iconic pieces in the classics of international design.



02

01 Pavilion of the Spanish Republic,
International Exhibition in Paris 1937.
Photo by François Kollar

02 Self-portrait (Josep Torres Clavé)

Catalana 1942

Germán Rodríguez Arias
Barcelona 1902 - 1987



During his time in Chile, German Rodríguez Arias met Pablo Neruda and struck up a long-lasting friendship with him.

Among others, Rodríguez Arias designed the house at Chascona and the extension of Isla Negra, two of the poet's homes. The Catalana armchair formed part of the furniture that the architect and designer created for Isla Negra.

Mobles 114 has revived the Catalana armchair by Rodriguez Arias following the original design as closely as possible.



03

Rodríguez Arias designed several houses for Pablo Neruda in Chile, among others, the enlargement of Isla Negra, and part of the furniture, such as the Catalana armchair.



03 Pablo Neruda's house in Chile.
Photo by Díaz Wichmann

04 Germán Rodríguez Arias and his wife

04

MMS 1963

Miguel Milá
Barcelona 1931



MMS is the reissue of the Superponible table, a lightweight, small and stackable side table, suitable for any place in the house due to its shape and various possible compositions, such as a bedside table, auxiliary table or coffee table in the living room or other spaces.

This piece of furniture has been re-released to underline the fact that the MMS 1963 table is one of our country's design classics.



05

MMS table was part of the furniture for Casa Pairal in Espolla, renovated by the architect José Antonio Coderch.



05 Casa Pairal, Espolla (1964)

06 Portrait of Miguel Milá
by Maria Espeus.

06

Jujol 1920

Josep Maria Jujol
Tarragona 1879 - Barcelona 1949



The Jujol table was designed between 1920 and 1927 by the architect Josep Maria Jujol. This is a reproduction of the table exhibited at the MNAC (National Art Museum of Catalonia).

It comes from the house where JM Jujol lived, in Rambla de Catalunya in Barcelona. Based on the way it was built, we can conclude that it's a prototype, a unique model which we have reproduced and now forms part of the Mobles 114 Classics catalogue.

Jujol 1920 is a side table that wants to be seen as a work of art; a versatile table that adds dignity, sobriety and elegance to any interior design.



07

The Jujol table is a re-edition of the one exhibited permanently at the MNAC (National Art Museum of Catalonia).

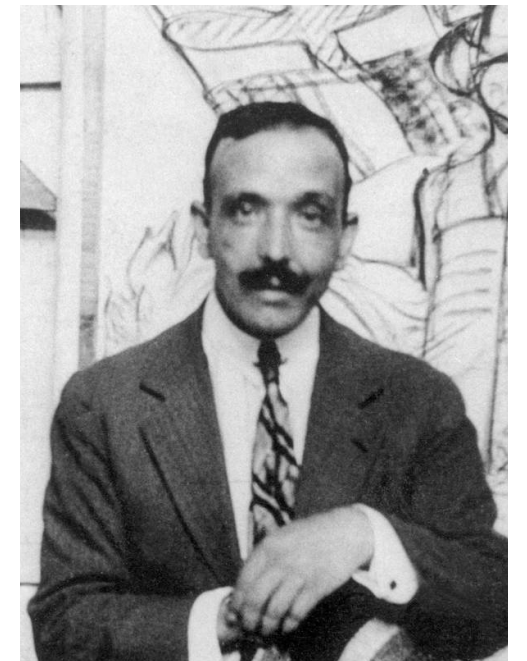

07 Permanent exhibition in MNAC (National Art Museum of Catalonia)

08 Portrait of Josep Maria Jujol.

08

Fil 1991

Álvaro Siza
Matosinhos, 1933

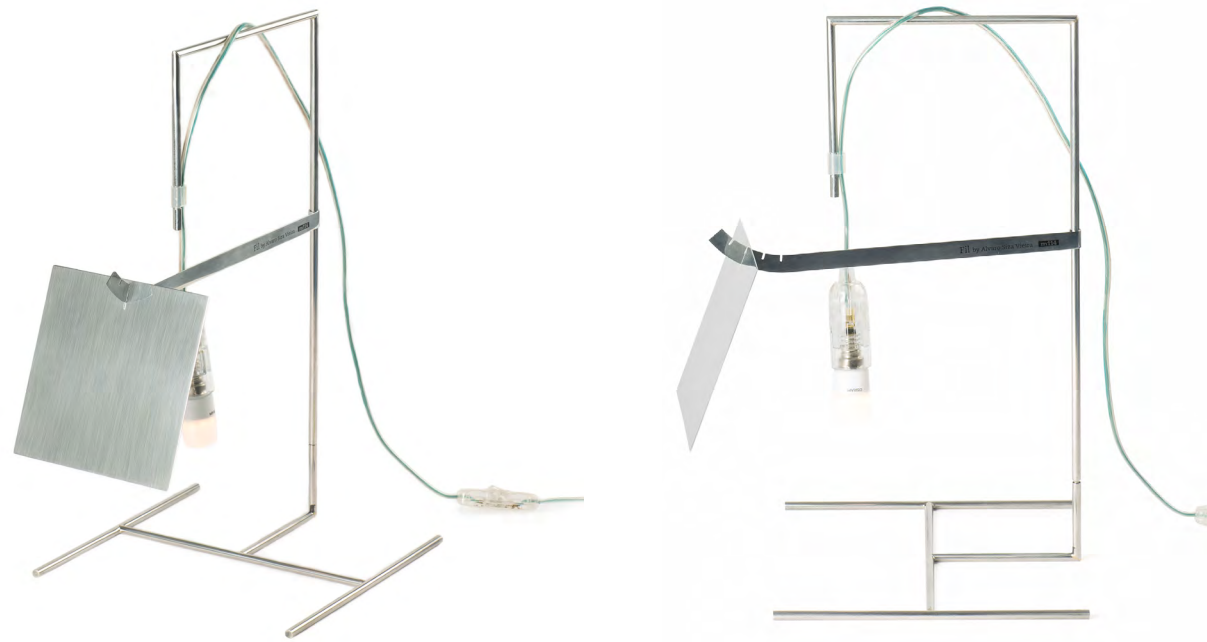

“Before there was electricity, in my grandparents’ house there were oil lamps with a rectangular plate protecting the flame from the front side. The result was an indirect light reflected on the wall, a fact that has always pleased the architect Álvaro Siza.”

– Eduardo Souto de Moura

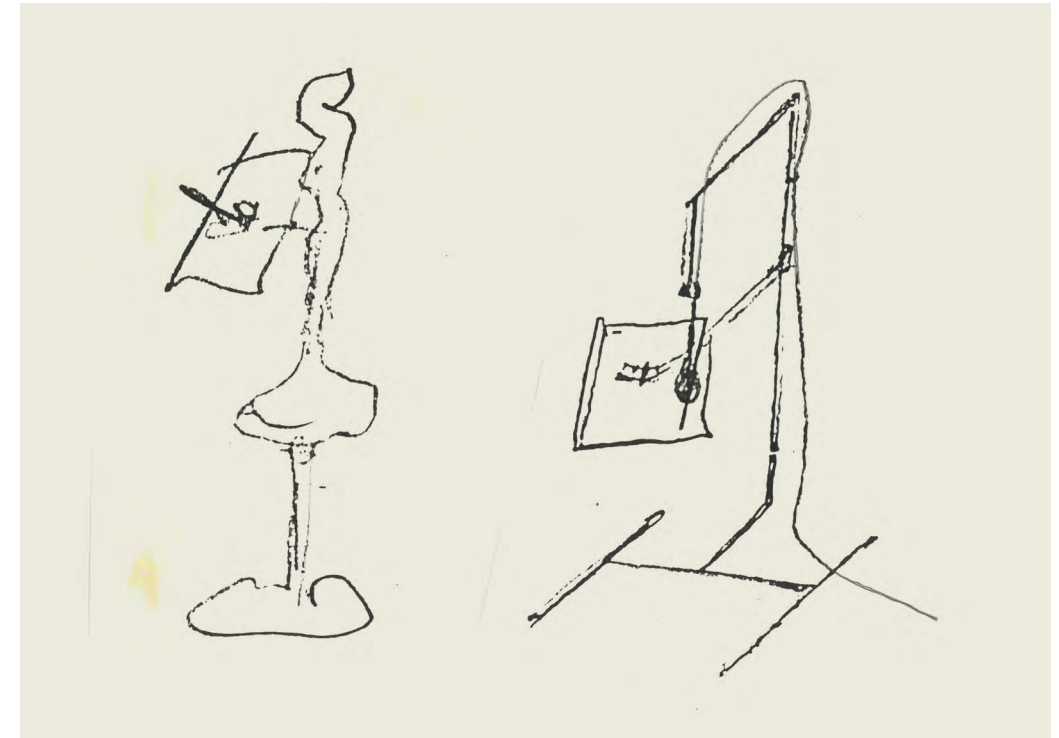

09

Fil is a table lamp designed in 1991 by the architect Alvaro Siza Vieira which reveals without pretence the essence of an electric light: a support, the electric wire with the lightbulb and a shade.

A light that forgoes ornaments, inspired by the evolution of brass or bronze oil lamps that included a shade to avoid dazzle.

Made of stainless steel, the Fil lamp by Siza Vieira forms part of the Classics catalogue of Mobles 114 thanks to its contemporary roots and in homage to one of today’s great architects.

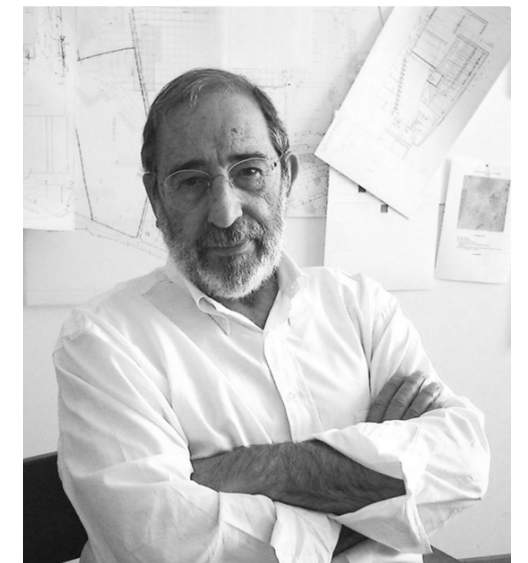

09 First sketches by Álvaro Siza

10 Portrait of Álvaro Siza.

10

Copenhaguen 1966

André Ricard
Barcelona, 1929

Copenhaguen ashtray is the result of a geometric design that uses the simple repetition of a cylinder.

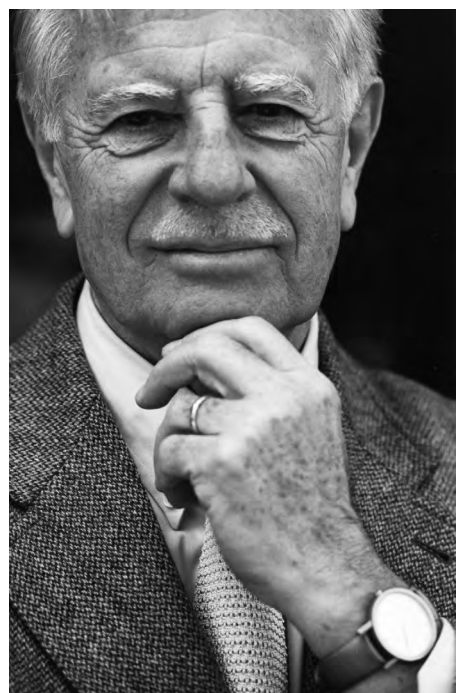

11



This is a hard-wearing, stackable ashtray that fulfils its function with utmost effectiveness. This design classic is in line with the goal of Mobles 114, which, for more than 20 years, has remained in the market to preserve our country's heritage in terms of both culture and design. The Copenhagen ashtray won the ADI-FAD Delta Silver Prize 1966.

Tong 1964

André Ricard
Barcelona, 1929

André Ricard designed these tongs in 1964 for ice cubes back in the day when plastic was a relatively new material.



12

11 Portrait of André Ricard.

12 First model of the ice tong by André Ricard (1964)

These ice tongs, relaunched in 2018, are an updated version of the ones designed by André Ricard in 1964.

A devotee of simplicity and functionalism, André Ricard designed these tongs for ice cubes back in the day when plastic was a relatively new material. This gave the designer the chance to rethink an object that had always been produced in the same way.

In Ricard's design, the tongs' shape is used to fulfill their purpose. His masterful solution takes advantage of the tong's leverage and the flexibility inherent in plastic.

Focused on shaping
Workspaces (p.18) *Hospitality* (p.29)
Public Spaces (p.41) and *Retail* (p.53)
with our products

Working, meeting, interacting

We devote a significant portion of our time to these endeavors.

We need workspaces that are well-lit, ergonomic and conducive to productivity, featuring designated work spaces, communal relaxation areas, meeting rooms and hubs for fostering personal connections.

At Mobles 114, we propose furniture that doesn't overshadow other elements yet stands the test of time. It's about manufacturing furniture with sustainable materials, ensuring they are durable and can be assembled and disassembled as many times as necessary without losing any of their features. This versatility allows our furniture to seamlessly integrate with existing pieces, enhancing both aesthetic and functionality, thus contributing to a pleasant and efficient work environment.





13



15

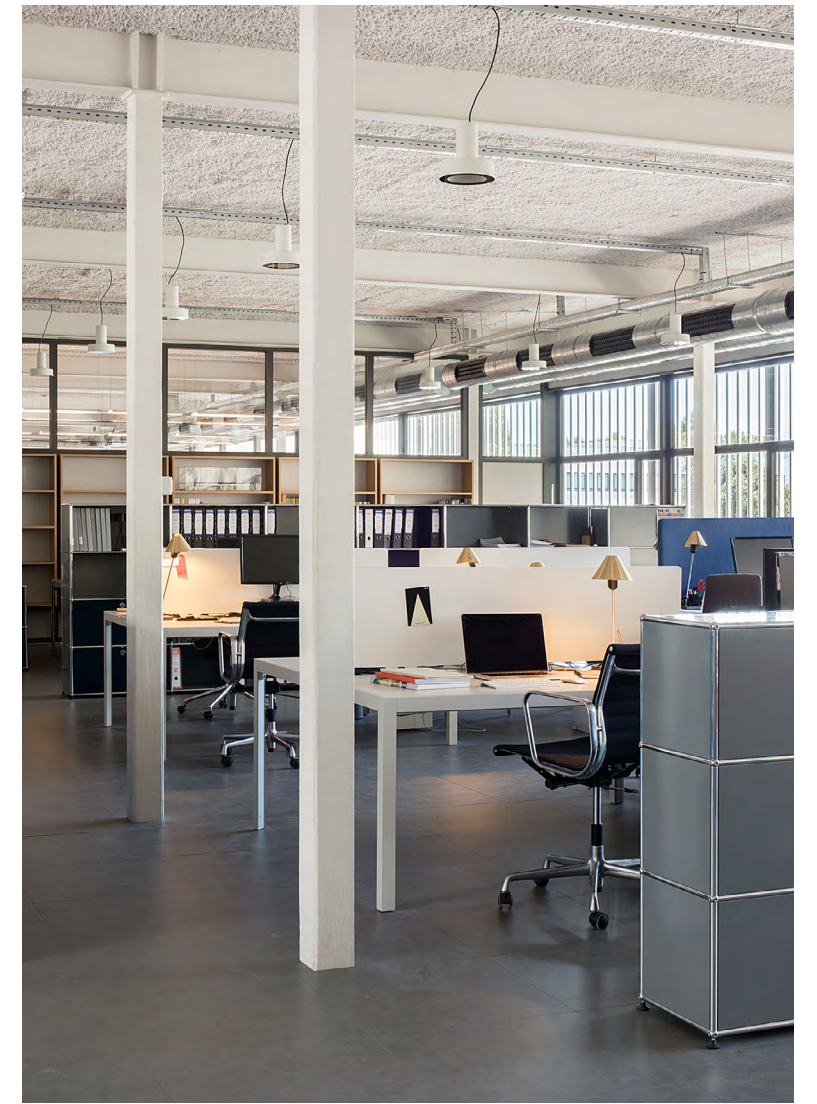

14

13 Pey Table System designed by JM Massana and JM Tremoleda.

14 Riga collection designed by JM Massana and JM Tremoleda.

15 Bambú coat stand designed by JM Massana and JM Tremoleda.





16

16 Tria Shelving System and Pey Table System designed by JM Massana and JM Tremoleda.

Green chairs designed by Javier Mariscal.

Pey Table System and Pey Central by JM Massana and JM Tremoleda.





17



19

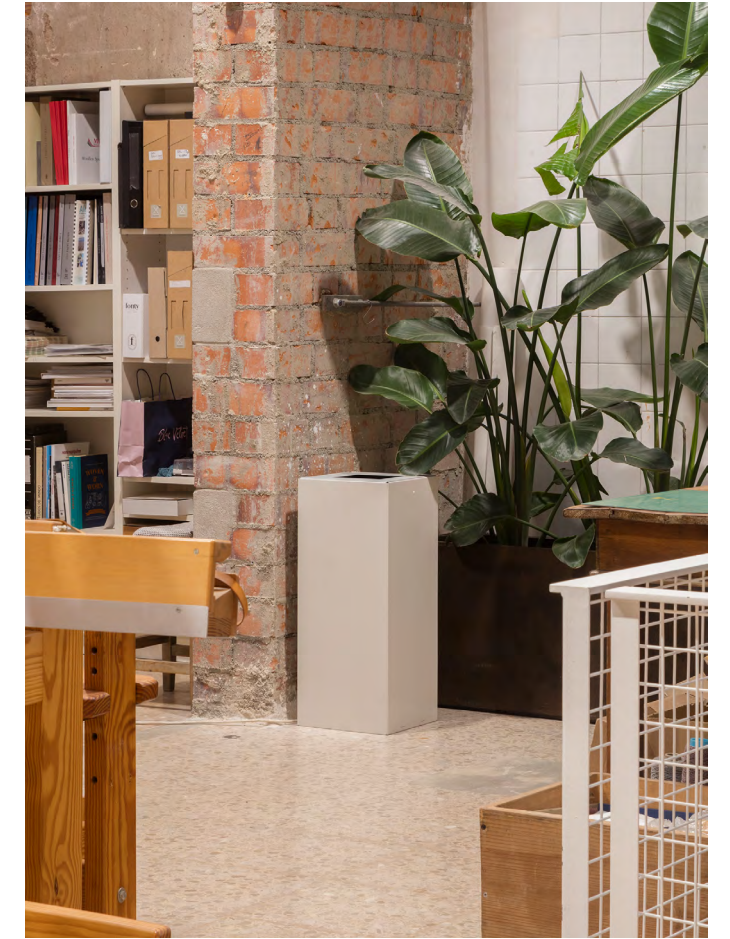

20



18

17 Tube chair by Eugeni Quitllet.

18 Nuta stool by Lluís Pau.

19 Green chair by Javier Mariscal

20 Riga bin by JM Massana and JM Tremoleda





21



22

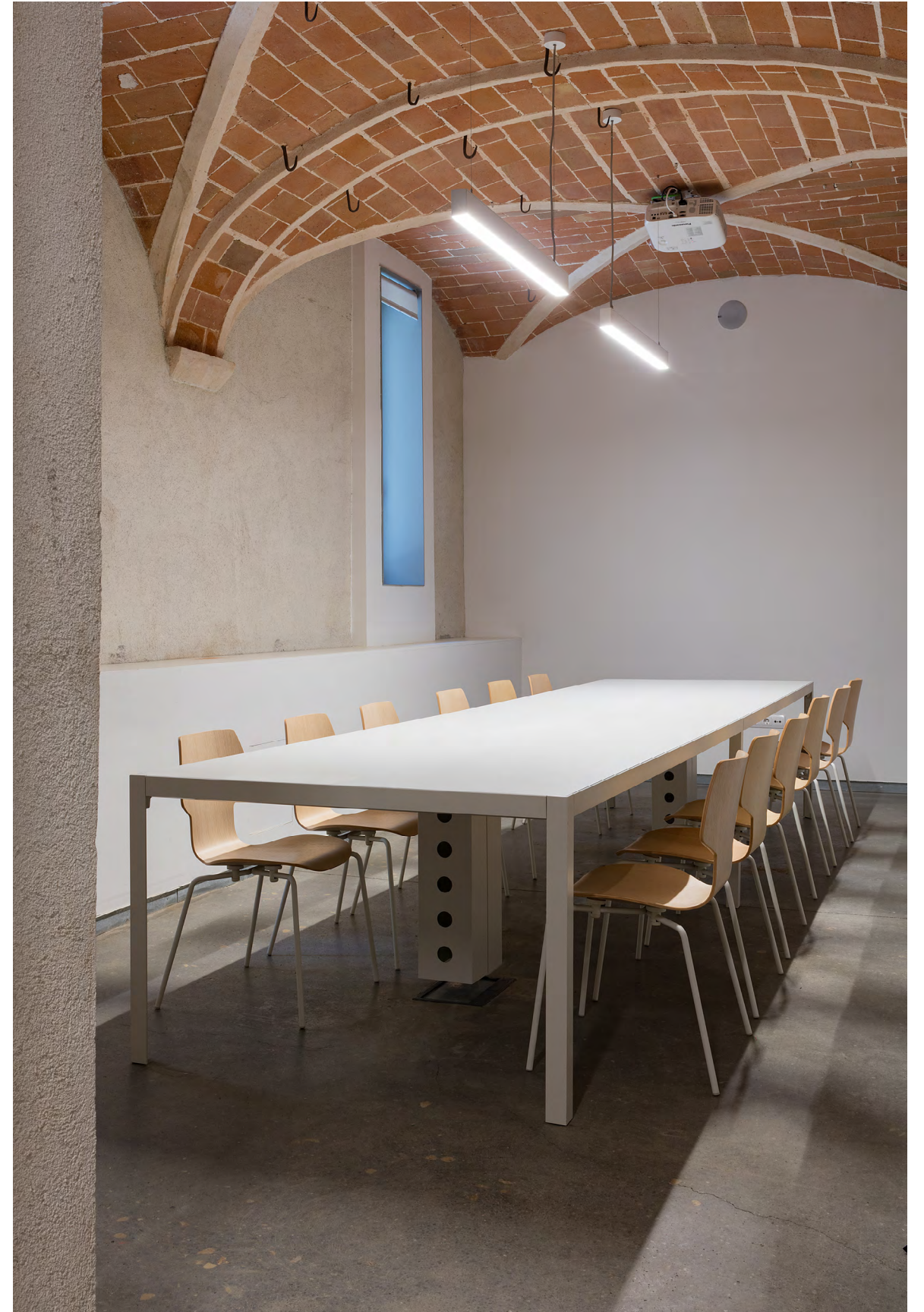

23

- 21 Taiga coat stand by Antoni Arola.
Nuta stool by Lluís Pau.
- 22 Tombal umbrella stand by Miguel Milá.
- 23 Pey Table System and Gràcia chairs
designed by JM Massana and
JM Tremoleda.

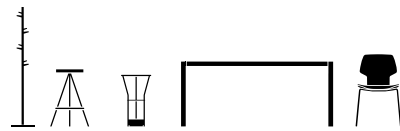



24



25



26

24 Mirac coat stand by JM Massana and JM Tremoleda.

25 Hulot coat stand by Joan Gaspar.

26 Torres Clavé 1934 armchair by Josep Maria Torres Clavé.

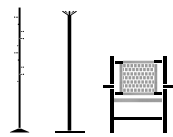



27



02

27 Pey Table System and Pey Storage
by JM Massana and JM Tremoleda.





28

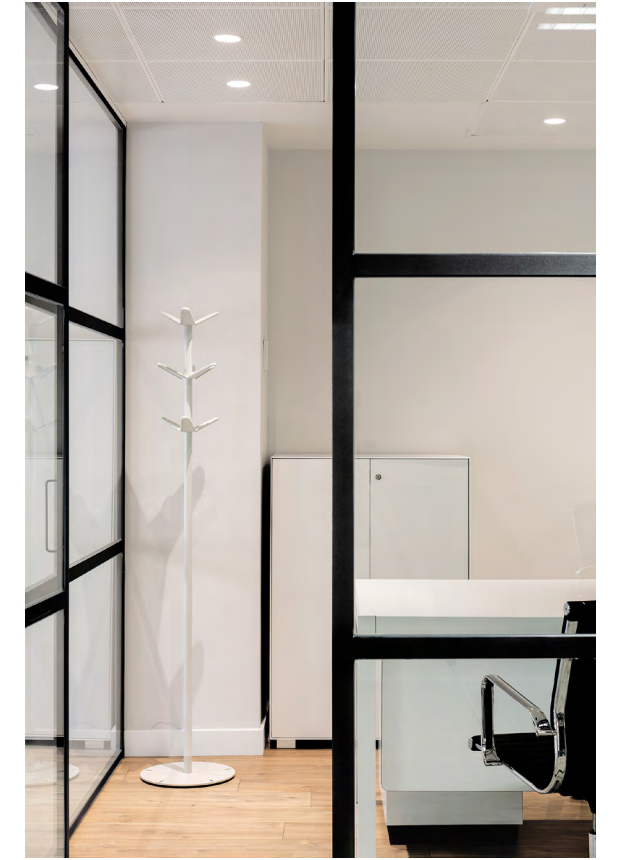

29

28 Pey Table System and Pey Storage
by JM Massana and JM Tremoleda.

29 Bambú coat stand and Pey Storage
by JM Massana and JM Tremoleda.

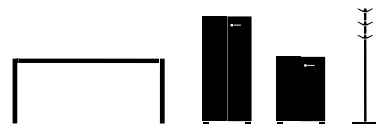



30



30 Pey Table System and Pey Storage
by JM Massana and JM Tremoleda.

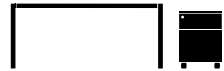



31



31 Tria Shelving System by JM Massana and JM Tremoleda.

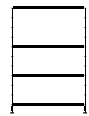



40



40 Mirac coat stand and Pey Table System
by JM Massana and JM Tremoleda.

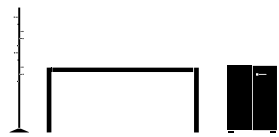

Hosting, traveling, feeling

Since the earliest days of mankind, we have journeyed away from our places of residence for various reasons. Whether for trade, pilgrimages or the desire to explore new worlds, the necessity arises to provide travelers with a place to sleep and eat.

Mobles 114 offers furniture that seamlessly integrates into new spaces, evoking a sense of familiarity and homeliness. Whether staying in a hotel, dining in a restaurant or enjoying a coffee in a bar, furniture should become an integral part of our experience. Our aim is to contribute to creating environments where people feel truly at home.



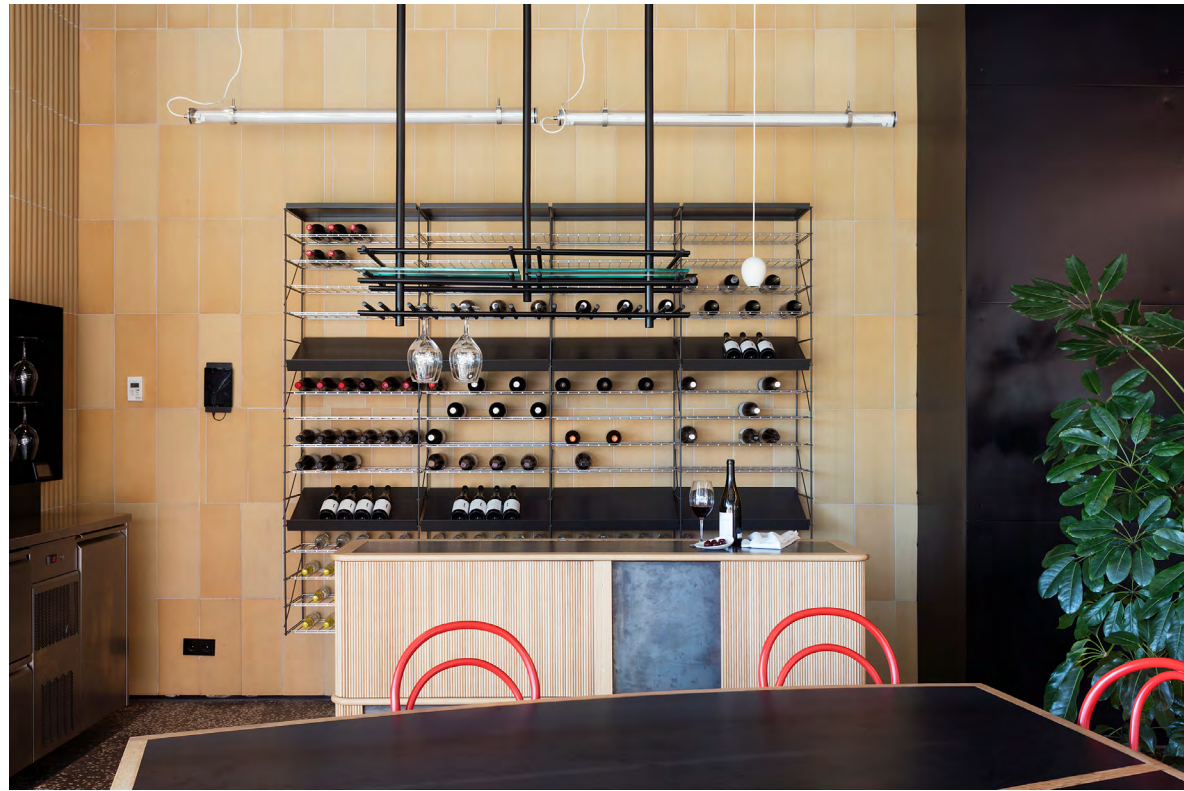

41



42



41 Tria Shelving System by JM Massana and JM Tremoleda.

42 Nuta stool by Lluís Pau

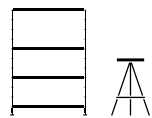



43

43 Gràcia chair designed by JM Massana and JM Tremoleda.

44 Green chair by Javier Mariscal.
Oxi Bistrot table by JM Massana and JM Tremoleda.



44





45

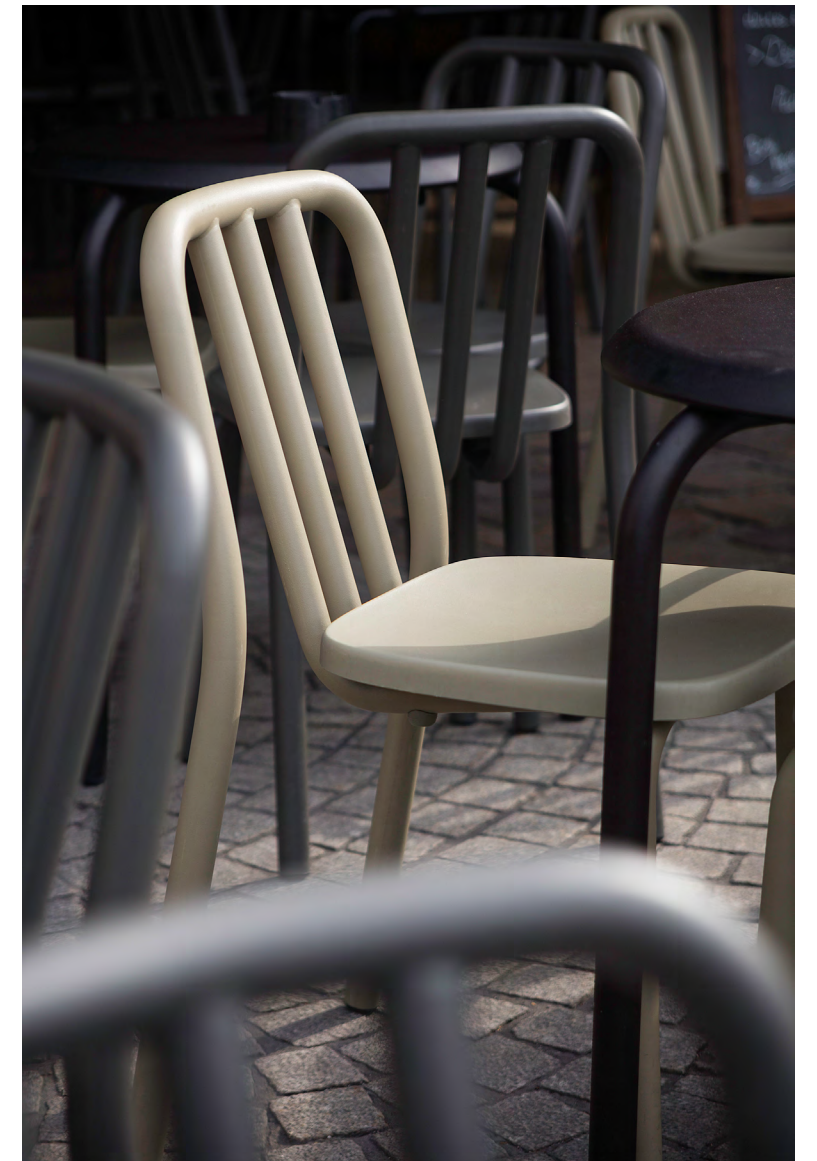

45 Tube collection designed by Eugeni Quitllet.





47



46

46 Gràcia chair designed by JM Massana and JM Tremoleda.
47 Riga ashtray by JM Massana and JM Tremoleda.





48

48 Rambla collection designed by Martin Azúa

49 Nuta stool by Lluís Pau
Oxi Bistrot table by JM Massana and JM Tremoleda.



49



50



50 Tube collection designed by Eugeni Quitllet





51



52

52 Nuta stool by Lluís Pau.

53 Green chair by Javier Mariscal.
Oxi Bistrot table by JM Massana
and JM Tremoleda.



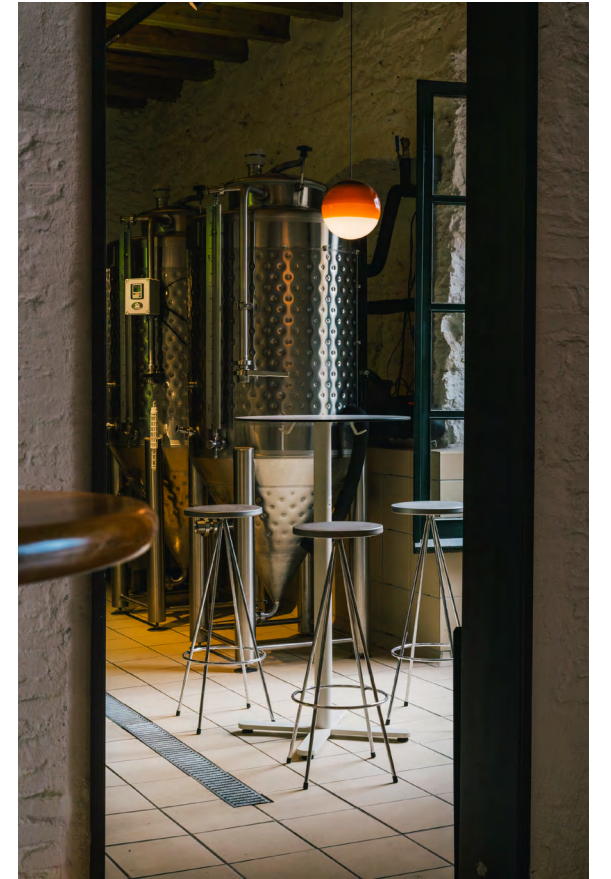

54

55



53

- 53 Riga ashtray designed by JM Massana and JM Tremoleda.
- 54 Tube collection by Eugeni Quitllet.
- 55 Nuta stool by Lluís Pau.
Oxi Bistrot table by JM Massana and JM Tremoleda.

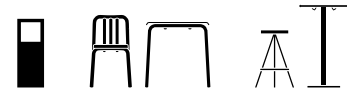





56

56 Rambla chair designed by Martín Azúa.



57 Nuta stools by Lluís Pau.



57

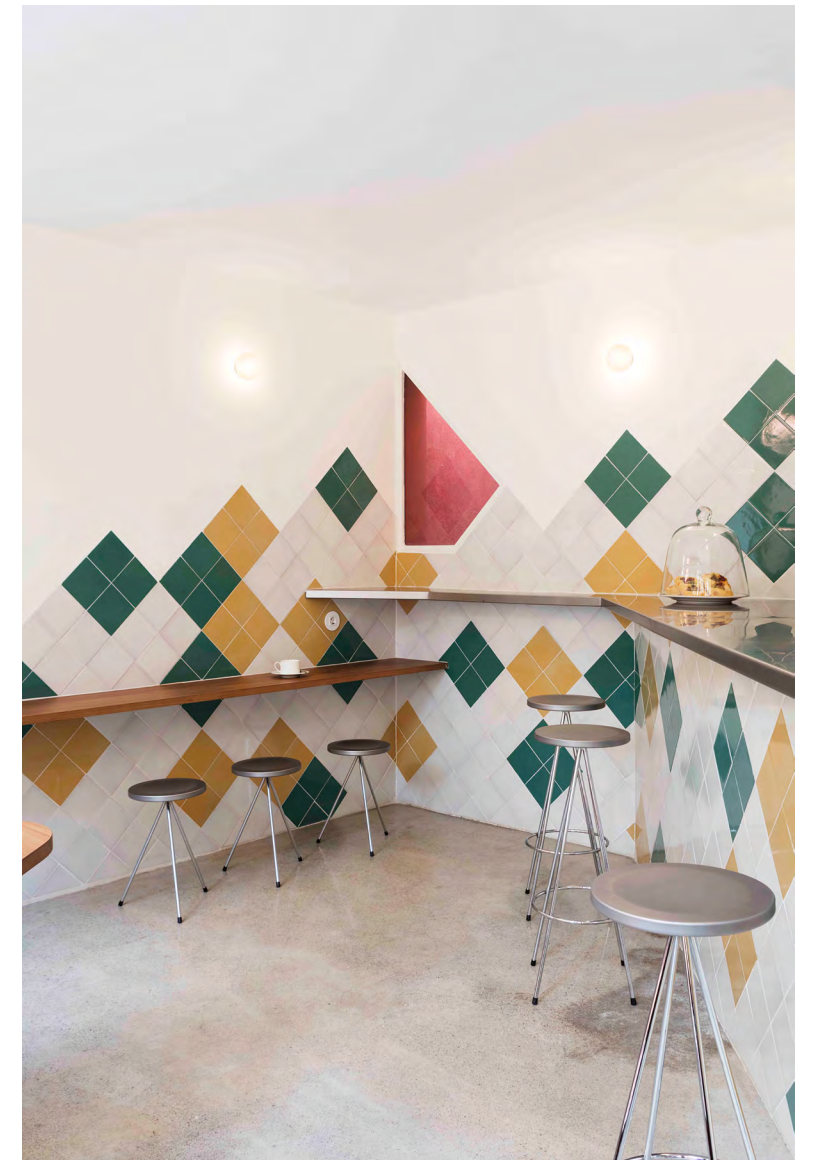



58

58 Ona coat rack designed by Montse Padrós and Carles Riart.

59 Tombal umbrella stand by Miguel Milá.

60 Green chair by Javier Mariscal.



59



60

Participating, exchanging, transmitting

Since the dawn of mankind, humans have organized themselves into families and social groups. We engage, exchange and communicate, and these interactions define us as social beings.

At Mobles 114, we advocate the idea that collective spaces should also prioritize comfort. We provide furniture that is durable and resilient, with a clear focus on offering comfort, functionality, adaptability, technical capabilities, material resilience and versatility. Our furniture is designed beyond passing fancies with the aim of providing a long and useful life cycle.





61

61 Gràcia chair designed by JM Massana and JM Tremoleda.

62 Riga recycling bin designed by JM Massana and JM Tremoleda.

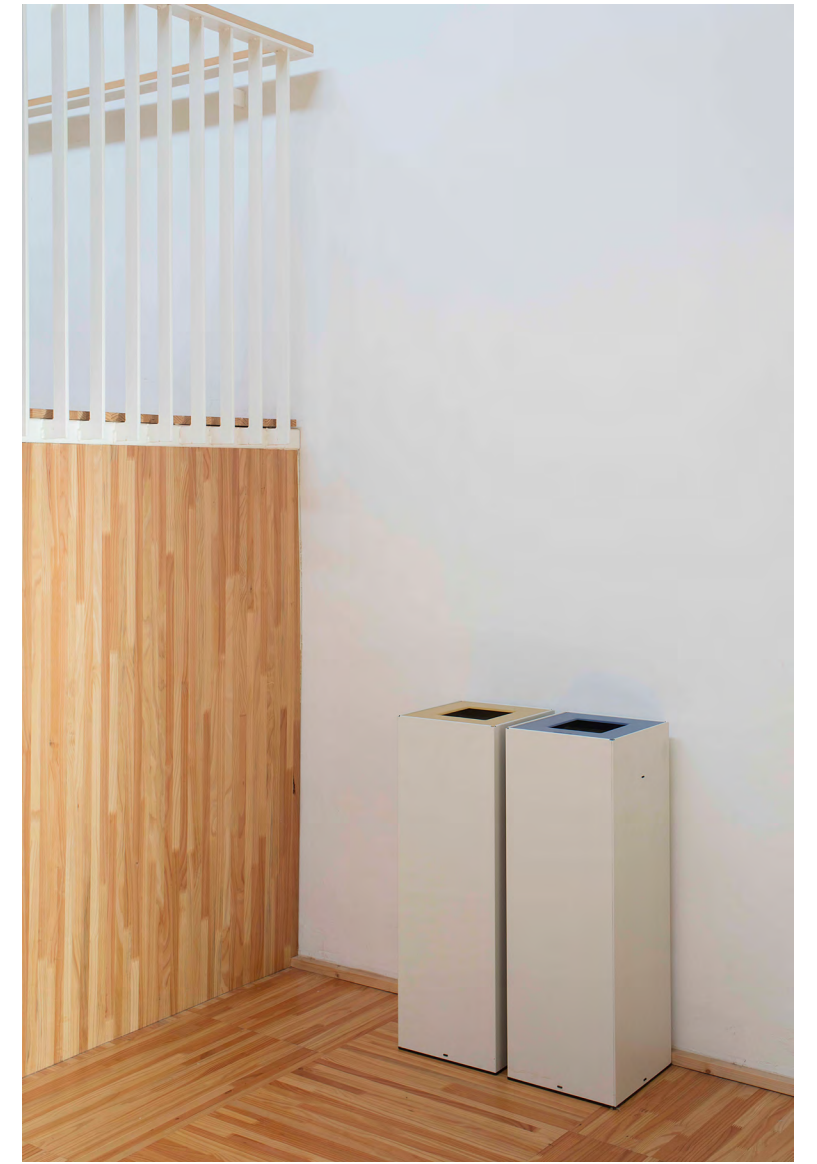

62



63

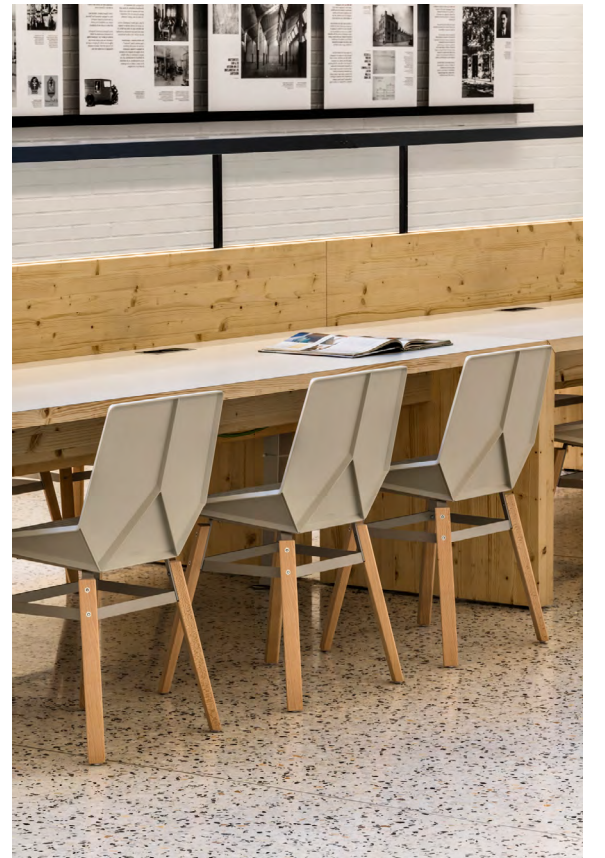

63 Pey Table System designed by JM Massana and JM Tremoleda.
Green chair by Javier Mariscal.

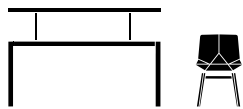



64



65

64 Pey Table System and Gràcia chair designed by JM Massana and JM Tremoleda.

Taiga coat stand by Antoni Arola.

65 Riga bin by JM Massana and JM Tremoleda.

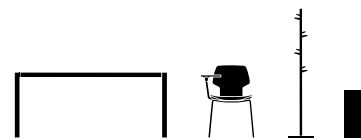

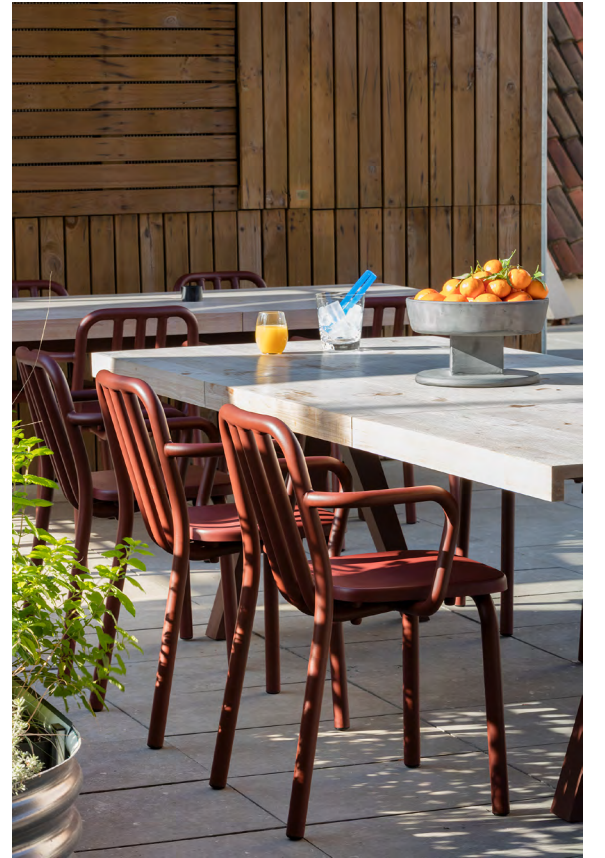

66



66 Tube collection designed by Eugeni Quitllet





67



69



68

67 Platea umbrella stand by JM Massana and JM Tremoleda.

68 Rambla collection designed by Martín Azúa.

69 Forc coat stand by Lagranja Design.

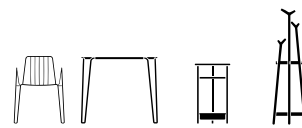



70



70 Pey Table System, Gràcia chair and Riga bin designed by JM Massana and JM Tremoleda.





71



71 Tria Shelving System designed by JM Massana and JM Tremoleda.
 Forc coat stand by Lagranja Design.

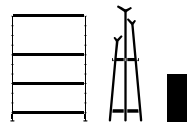

72 Riga bin by JM Massana and JM Tremoleda.



72



73

73 Forc coat stand designed by Lagranja Design.
Om armchair by Martín Azúa.
Oxi Bistrot table by JM Massana and JM Tremoleda.
74 Nuta stool by Lluís Pau.

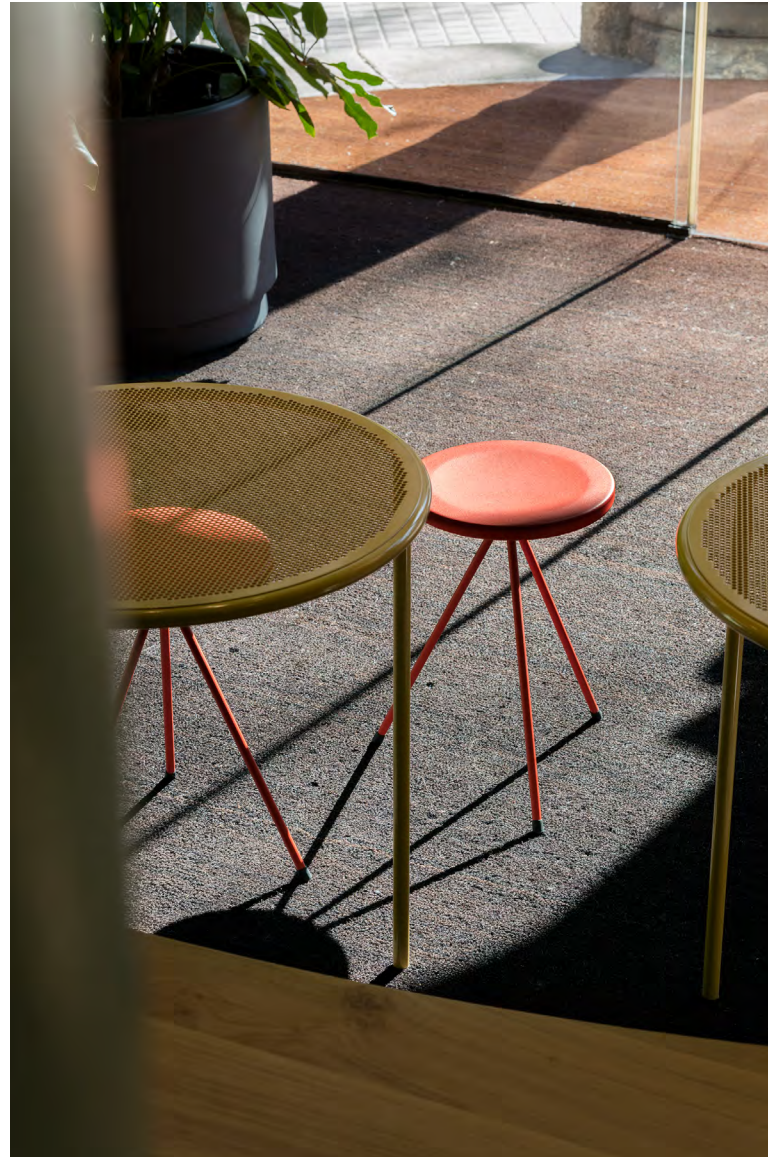

74





75

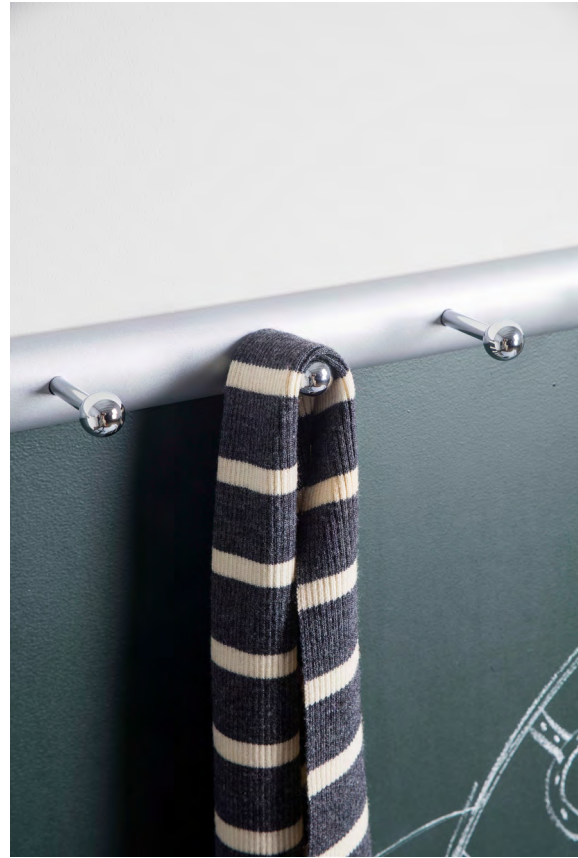

75 Mirac multiple wall coat rack designed by JM Massana and JM Tremoleda.
Nuta stool by Lluís Pau.

76 Pey Table System by JM Massana and JM Tremoleda.



76

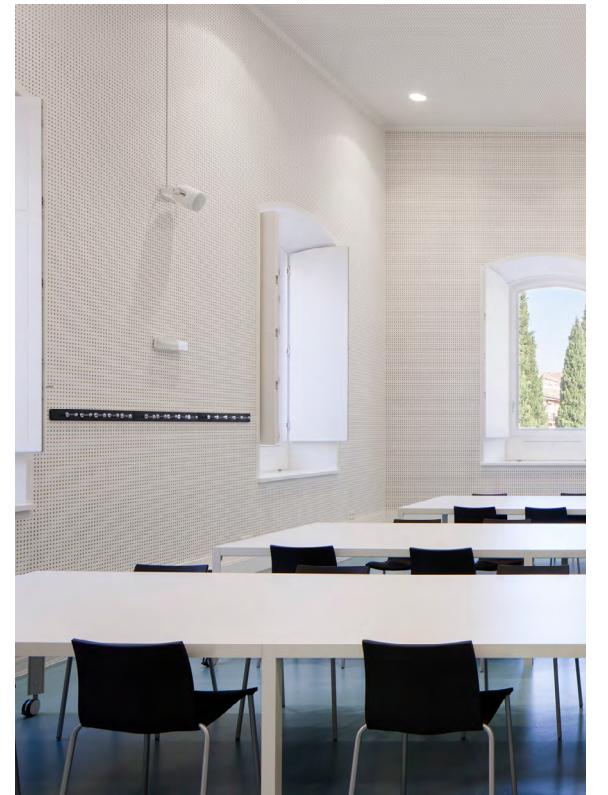



77



79



80



78

- 77 Tube collection designed by Eugeni Quitllet.
- 78 Om armchair by Martín Azúa.
- 79 Hulot coat stand by Joan Gaspar.
Pey Table System by JM Massana and JM Tremoleda.
Green chair by Javier Mariscal.
- 80 Riga bin by JM Massana and JM Tremoleda.

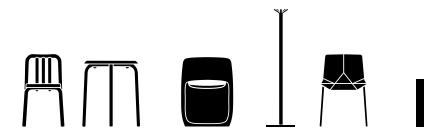



81



82



83

81 Gràcia collection designed by JM Massana and JM Tremoleda.

82 Forc coat stand designed by Lagranja Design.

83 Torres Clavé 1934 armchair by Josep Maria Torres Clavé.

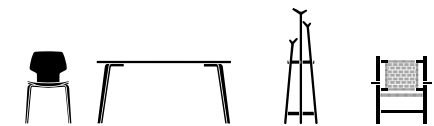

Displaying, offering, exchanging

From time immemorial, humans have traveled to exchange goods. This is the origin of commerce (“commercium” in Latin), meaning the exchange of goods and services among individuals.

In this vein, Mobles 114 presents furniture solutions seamlessly blending into new commercial landscapes, as though they’ve been an integral part since inception. Be it within a local boutique or a bustling shopping complex, furniture ought to intertwine with the customer experience seamlessly. The objective is to contribute towards crafting commercial environments where individuals feel at ease and catered for, thus enriching their shopping experience.





84

84 Tria Shelving System by JM Massana and JM Tremoleda.

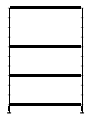







85



86



87



88

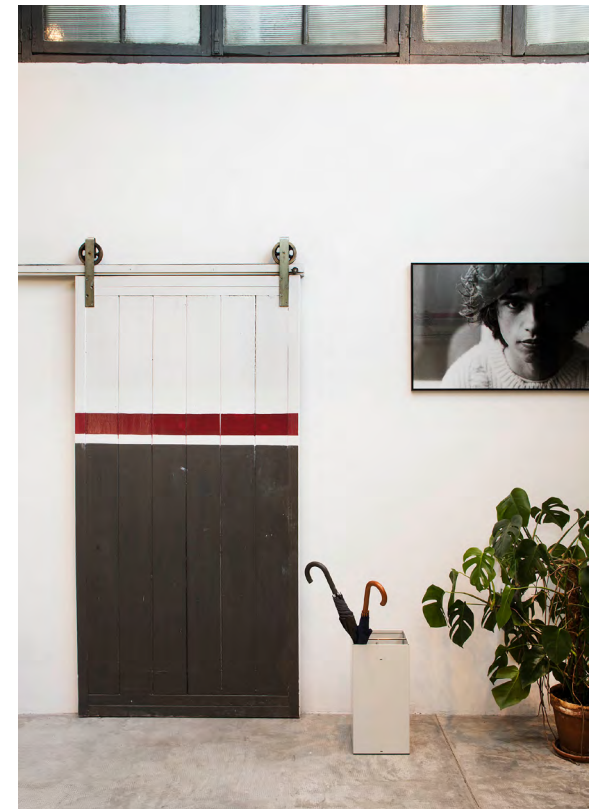

89

85 Taiga coat stand by Antoni Arola.

86 Om armchair by Martin Azúa.

87 Mirac coat stand by JM Massana and JM Tremoleda.

88 Green chair by Javier Mariscal.

89 Riga umbrella stand by JM Massana and JM Tremoleda.

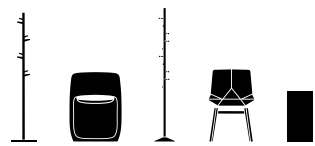

Our products

JM Massana & JM Tremoleda

Pey Table System

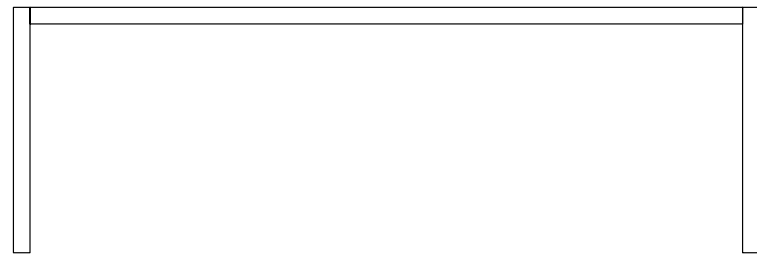

60-555L x 60-180W x 76/90H (cm)

Structure



HPL Table Top



Suitable for work environments, meeting rooms and educational spaces, the Pey Table System is also ideal for meeting the needs of workplaces.

Rationality is one of the fundamental aspects of the Pey system, designed with simplicity to maximize the technical benefits of the materials used in its design. This characteristic allows for the creation of large-format tables for collaborative environments, complying

with regulations and certifications that guarantee high quality and durability.

Moreover, the system offers personalized solutions through its configurable design, which includes integrated power systems with all the necessary elements for wiring, as well as accessories for the structure, such as wheels and table joining elements. It also provides accessories such as drawers and cabinets.





The Pey Table boasts a diverse range of configurations, featuring dimensions of up to 280 x 180 centimeters, all supported by just four legs. Ideal for collaborative environment where enough space is

essential for effective work, meetings or educational activities. Additionally, larger tables with six legs can be customized, reaching dimensions of up to 555 x 180 centimeters.

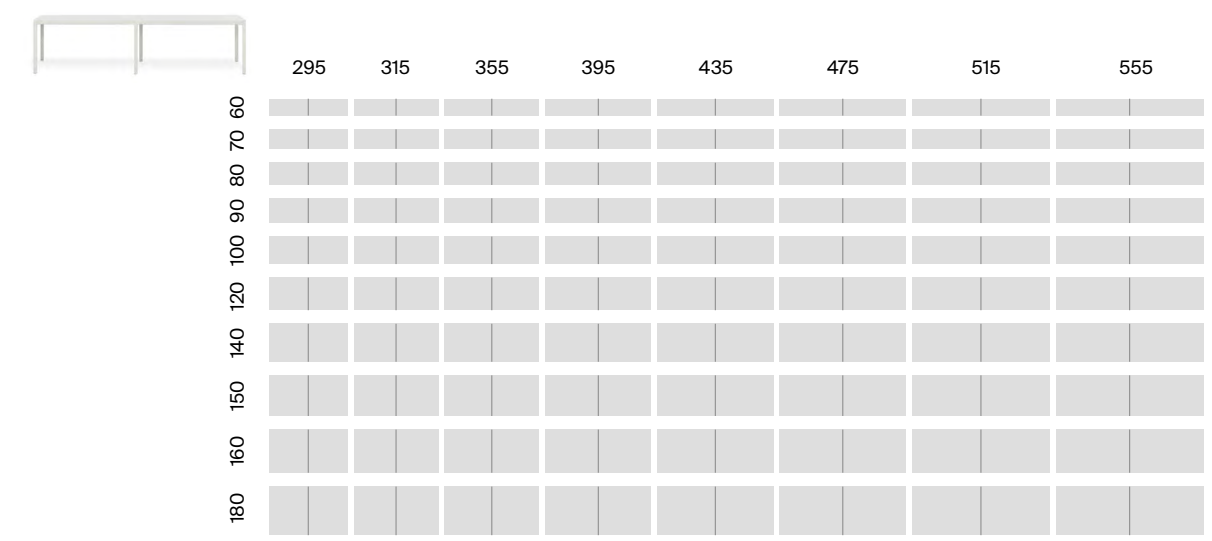
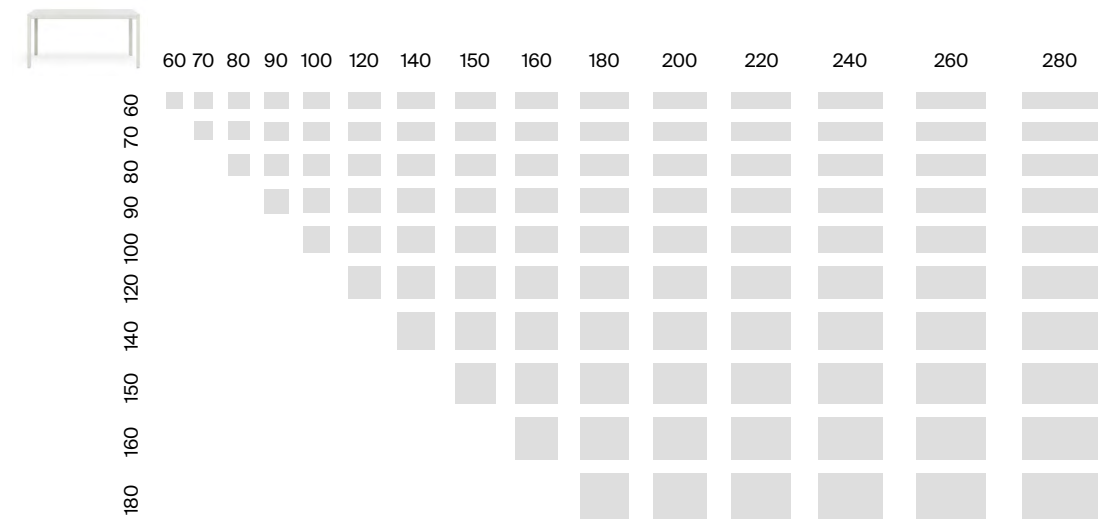

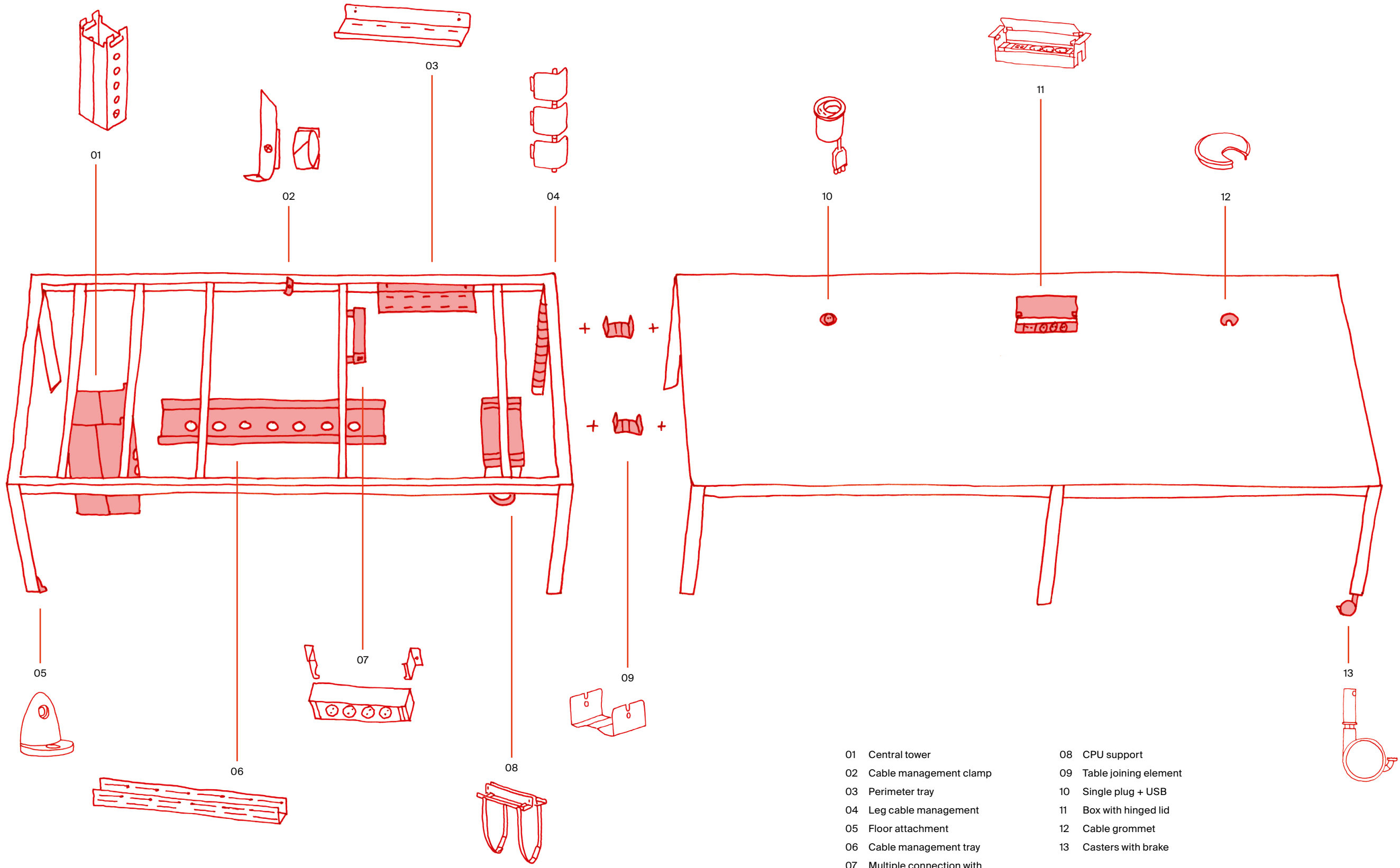

- 01 Central tower
- 02 Cable management clamp
- 03 Perimeter tray
- 04 Leg cable management
- 05 Floor attachment
- 06 Cable management tray
- 07 Multiple connection with underdesk bracket
- 08 CPU support
- 09 Table joining element
- 10 Single plug + USB
- 11 Box with hinged lid
- 12 Cable grommet
- 13 Casters with brake

Pey Table System features a pedestal with drawers and metal cabinets known for their robustness and durability. Made from high-quality materials, they are designed to withstand intensive daily use, protecting important documents and equipment. Their metal construction makes them particularly suitable for office environments, where durability is as crucial as design.



JM Massana & JM Tremoleda

Tria Shelving System

Wall

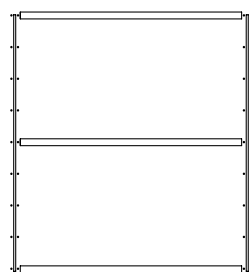

60/90L x 24W x 100/150/200H (cm)
60/90L x 36W x 34/100/150/200H (cm)

Floor (wall mounted)

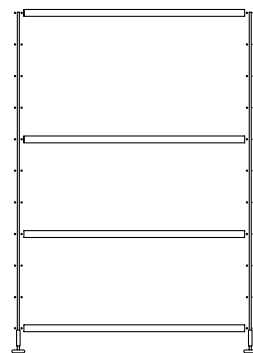

60/90L x 24/36W x 73/135/198H (cm)

Freestanding

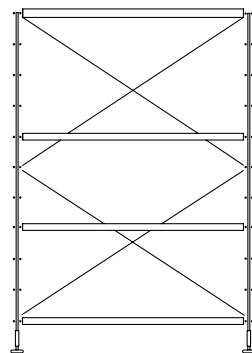

60/90L x 36W x 73/135 (cm)

Side Panels



Shelves



The Tria modular shelving system is built on versatility and flexibility, addressing all daily storage challenges. With its simple yet sleek design, this functional modular system seamlessly adapts to a wide range of spaces, from domestic to public settings.

Offering limitless configuration possibilities thanks to its array of

elements and accessories, Tria's online configurator enables users to personalize compositions by combining materials, colours and accessories. This provides tailored solutions to a variety of functional and decorative needs in areas such as waiting rooms, hallways, libraries, offices, retail spaces and reading rooms.



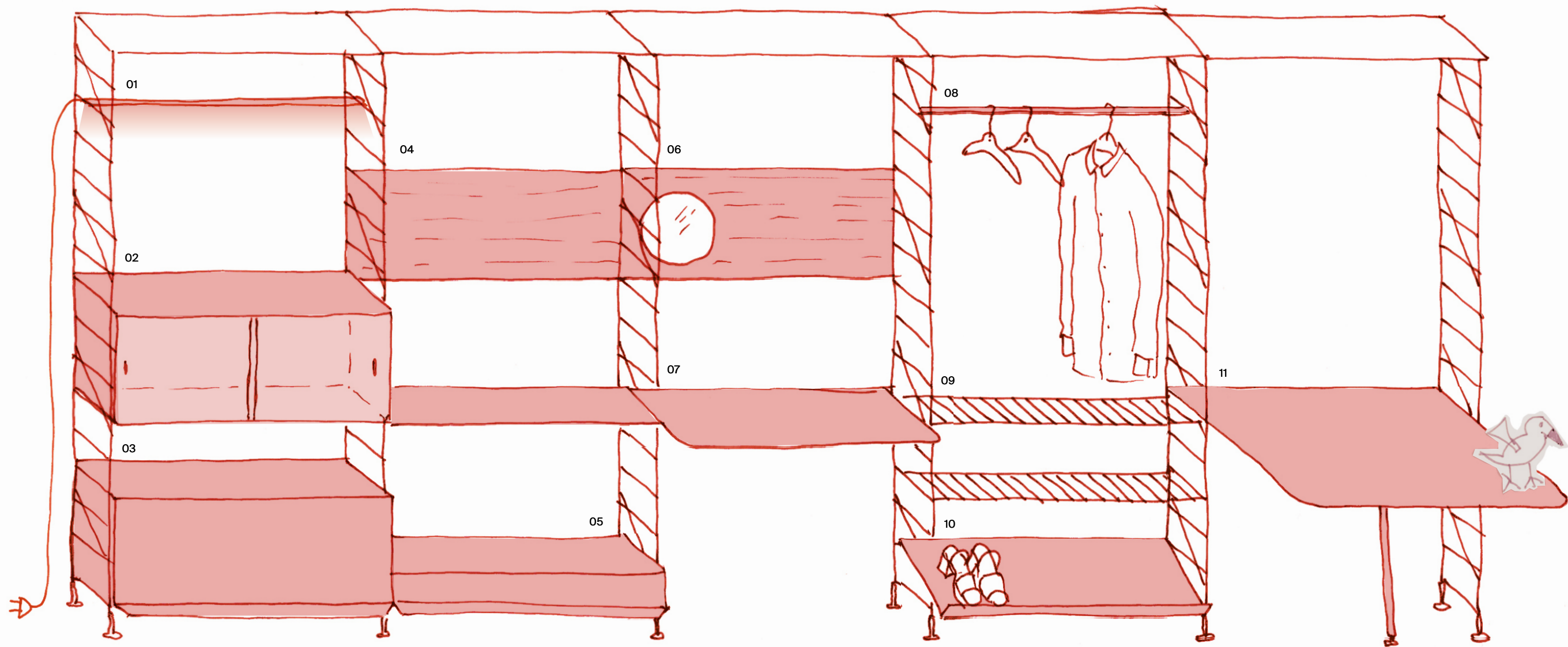

- | | | | | |
|--------------------|---------------|----------------------|-----------------------|----------|
| 01 Linear light | 04 Back panel | 06 Mirror back panel | 08 Clothes hanger bar | 11 Table |
| 02 Display cabinet | 05 Drawer | 07 Desk | 09 Grid shelf | |
| 03 Cabinet | | | 10 Inclined shelf | |



JM Massana & JM Tremoleda

Gràcia Collection



120–220L x 80–100W x 74H (cm)

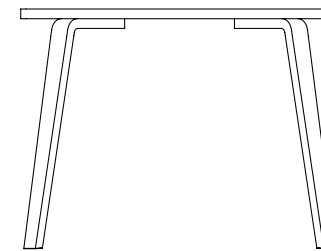

80–120L x 80–120W x 74H (cm)

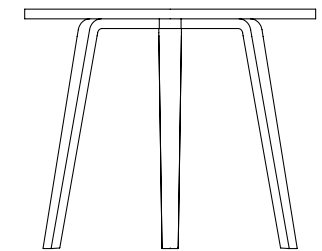

Ø80–120 x 74H (cm)

Structure



The Gràcia family comprises tables and chairs crafted from premium quality noble woods.

These tables, characterized by their generous dimensions, stand out by providing a blend of robustness and longevity, making them ideally suited for both office and hospitality settings. The

subtly arranged curved legs lend the table a visually light appearance. This design concept introduces a table seemingly devoid of structure, thus allowing the inherent constructive nature of the plywood to be prominently displayed.

The extensive range of sizes available for this table renders it one of the most versatile choices in the market, providing options in round, square and rectangular shapes.

It can include an integrated cable management hole, a connecting piece to create multiple workspaces or a cable tray, thus efficiently covering the needs of any office environment.

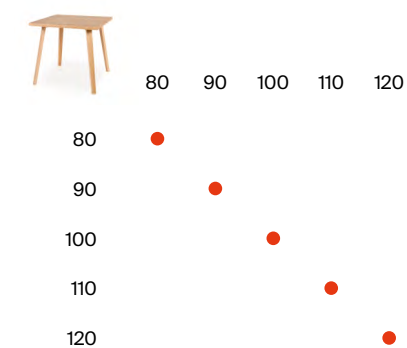
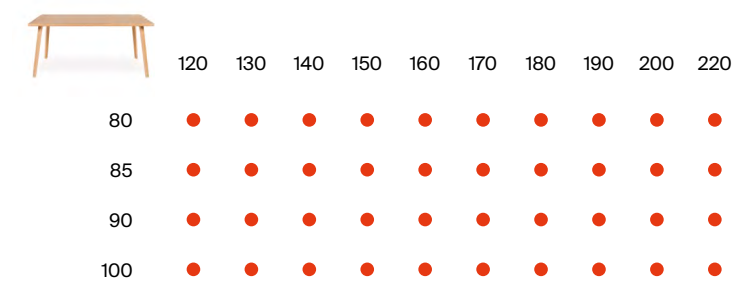

JM Massana & JM Tremoleda

Gràcia Collection

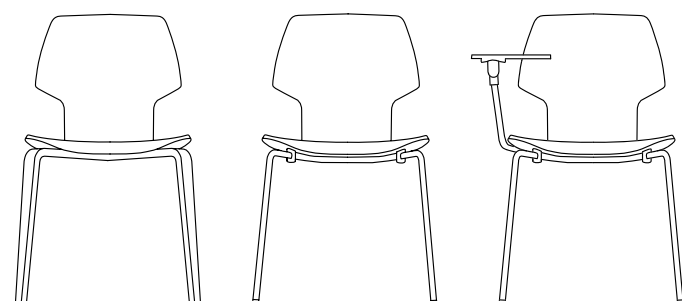

52L x 53W x 83H (cm)

Structure



Seat



Cushion



Gracia is a chair that harmoniously blends wooden and metal legs, featuring a plush polyurethane cushion available in four colors or upholstered with our curated selection of fabrics. Its versatile design effortlessly complements various styles and decor schemes, infusing

comfort, warmth and sophistication into any setting. Meticulously crafted details ensure exceptional ergonomics, inviting users to relax and indulge in moments of sheer comfort and delight.



Javier Mariscal

Green Collection

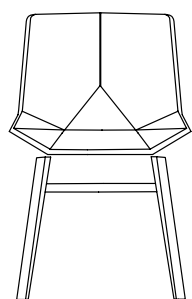

47L x 43W x 79H (cm)

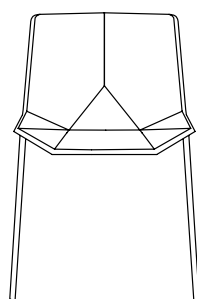

56L x 50W x 79H (cm)

Structure



Seat



The Green Eco and Green Colors chair collection is a project born with the commitment to improve quality of life and the environment. Sensitive to this value, Mobles 114 and Javier Mariscal, in the Eco version, have interpreted

and added originality to a propylene chair produced with 100% recycled and recyclable materials: polypropylene from industrial waste.



Martín Azúa

Rambla Collection

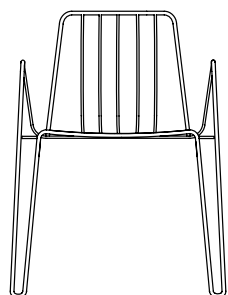

55L x 54W x 77H (cm)

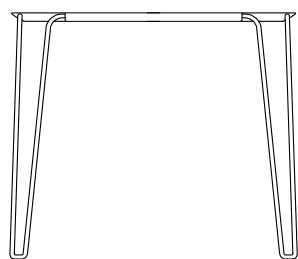

85L x 85W x 74H (cm)

Structure



The Rambla collection takes its conceptual inspiration from the seats used in one of the most emblematic streets in the city of Barcelona: the Rambla. A promenade that runs from the very heart of the city to the waters of the

port; that used to have stackable chairs you could hire for a while, to have a rest or chat, very often turning into an improvised agora.



Eugeni Quitllet

Tube Collection

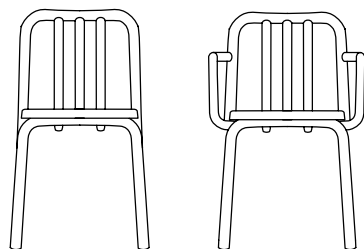

46L x 49W x 80H (cm)

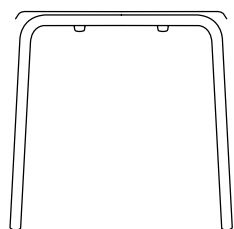

70L x 70W x 73H (cm)

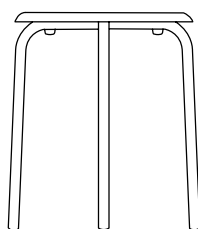

Ø60 x 73H (cm)

Structure



Tube chair and Tube tables deliberately conceal their virtues. Simple on the outside, smart on the inside: they are hardwearing, suitable for both indoors and out, stackable and easy to maintain.

A chair that's perfect for hospitality and catering projects.





JM Massana & JM Tremoleda

Danesa

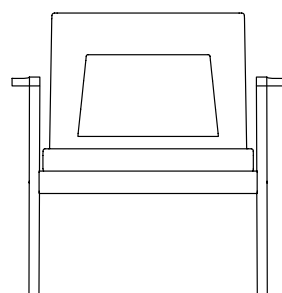

75L x 75,4W x 78H (cm)

Structure



Seat, backrest and cushion



This chair has a backrest consisting of two different parts: a cushion that includes magnets for the height to be adjusted backrest, and the backrest itself, which promotes exceptional comfort thanks to its width and the quality of its cover. These

two elements allow the armchair to adapt to each person and to every way of sitting for long periods of time.



Martín Azúa

Om

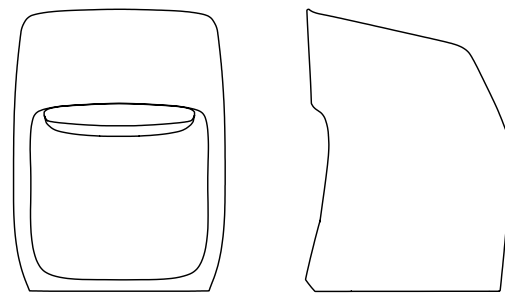

57L x 52W x 75H (cm)

Seat



Om Textile lounge chair can be made in fabric of one or two colours, with an extensive range of tones to adapt to the client's requirements. Its designer, Martín Azúa, has explored ergonomic possibilities in a sculptural, single-block

armchair that also has smooth, light lines. It endures intensive use in offices, hotels and rest areas.



Josep Maria Torres Clavé

Torres Clavé 1934

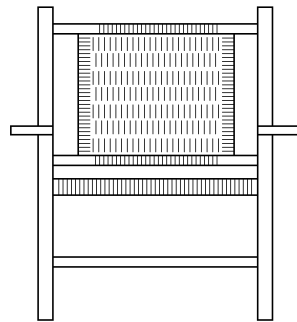

70Lx80Wx75H (cm)

Structure



The Torres Clavé armchair draws inspiration from the traditional chairs of Ibiza. With an oak frame and its seat and back upholstered with traditional cord, its formal touch adds a touch of elegance

to spaces in hotels, reception areas and waiting rooms, as well as reading areas in libraries and other special areas.



Lluís Pau

Nuta

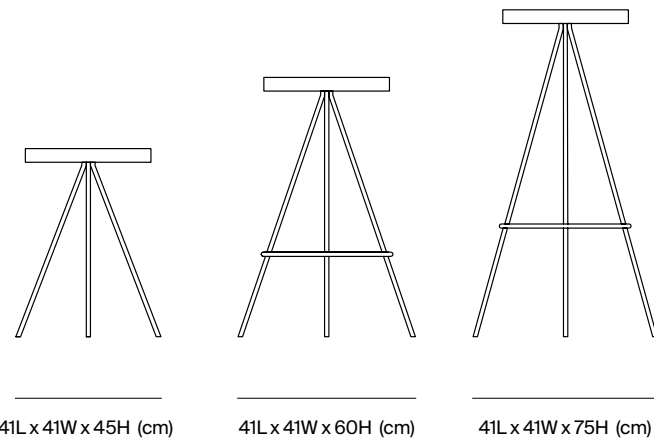

Structure



Seat



Nuta is a stool collection that stands out for its essential shape and lightness, as well as its adaptability to several different interior designs. Nuta stools are especially suitable as catering stools to furnish bars and cafeterias.

It's very stable in spite of its light shape and can perfectly withstand intensive use.



Lluís Pau

Nuta Colors

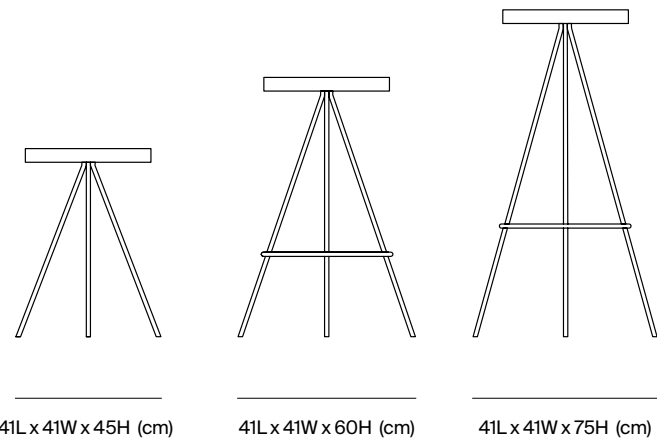

Structure and seat



An unpretentious design and a careful selection of finishes allow Nuta to furnish classic and contemporary spaces with elegance. Bars, restaurants, offices or public spaces are some of the environments where we can find the stool

in its different versions. A meticulous selection of colors in the single-color version helps complete any space. Also suitable for outdoors.



JM Massana & JM Tremoleda

Oxi Bistrot

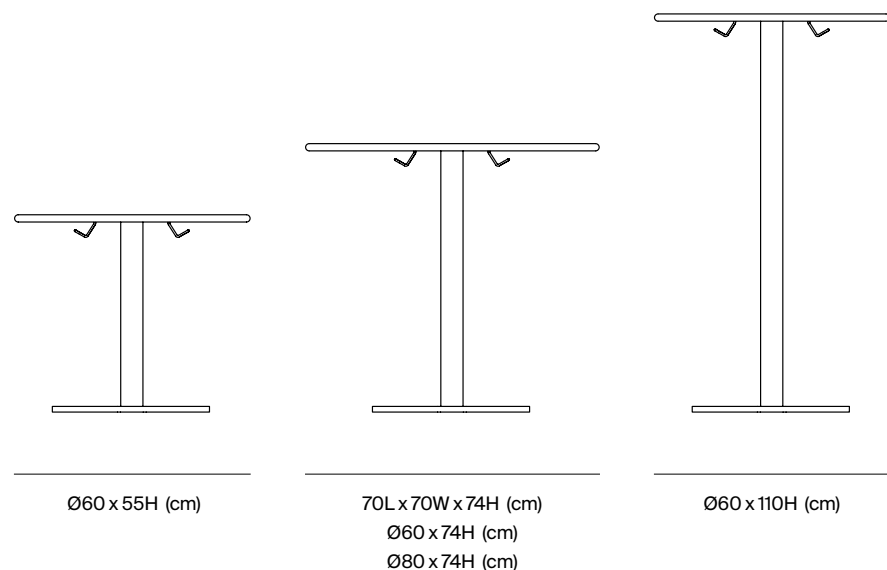

Structure



HPL Table top



Oxi Bistrot bar chair draws inspiration from the typical bistros of Paris. It's a modern, contemporary table with a look that adapts easily to a wide range of spaces, especially hotels and restaurants, both indoors and outdoors. It's also

perfect as a garden or terrace table, or for multipurpose spaces such as hotels and public or commercial areas.



JM Massana & JM Tremoleda

Pey Central

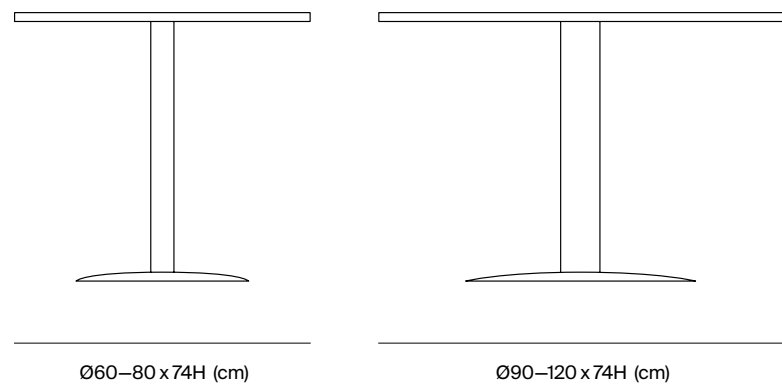

Structure



HPL Table top



Pey Central is a design table of minimalist lines, with an essential shape designed around a central base. A multipurpose round table with discreet form and size becomes an ideal complement for a meeting table in offices or work areas.



JM Massana & JM Tremoleda

Bambú

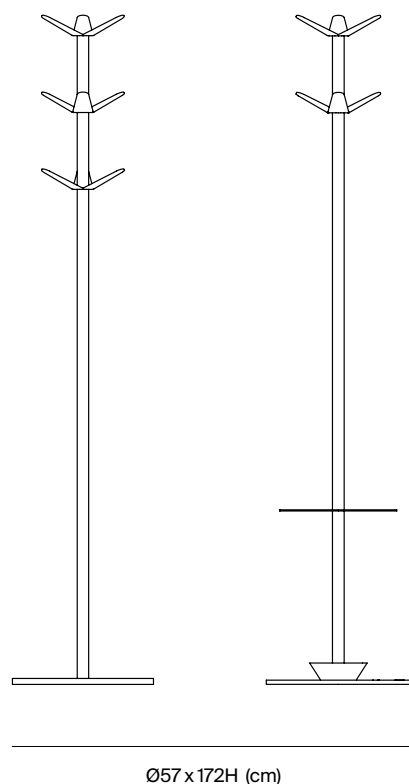

Structure



The separation of the pegs along the aluminium tube is reminiscent of the circles separating the elastic and static segments of bamboo canes. The natural

elegance of the plant creates a dialogue with this unpretentious design that conveys naturalness.



Lagranja Design

Forc

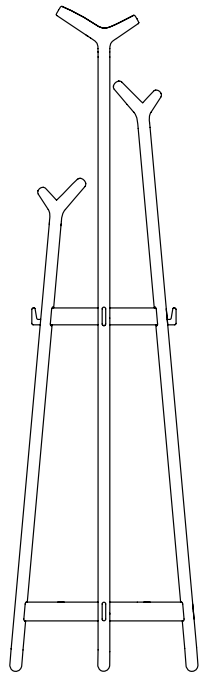

Ø47 x 176H (cm)

Structure



With the aim of suiting people's lives in both contemporary spaces and also more stylish zones in special or classic locations, this design coat stand by Lagranja Studio provides a practical, convenient beech coat stand. The

arrangement of the wooden pegs and their smooth shapes enable using them to hang all kinds of garments and accessories at differing heights.



Joan Gaspar

Hulot

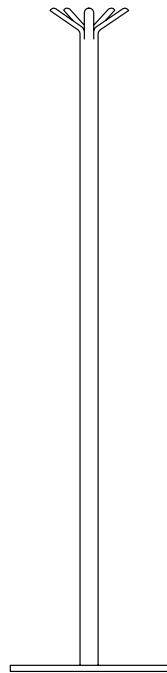

Ø50 x 175H (cm)

Structure



Eminently practical and unobtrusive, the Hulot coat stand is designed to fulfil its function to perfection. It adapts well to interior designs with a range of styles: modern, classic or casual. The smooth

lines of Hulot coat stands are designed to suit offices and receptions areas as well.



JM Massana & JM Tremoleda

Mirac

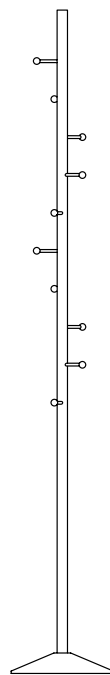

Ø30 x 190H (cm)

Structure



Recognised as an icon thanks to its modernity, Mirac coat stand is a leading coat stand in the world of interior and general design. The composition of the spherical chrome pegs arranged like stars in a constellation creates a celestial

image that led to the design being named after the second brightest star in the Andromeda constellation.



JM Massana & JM Tremoleda

Mirac Wall

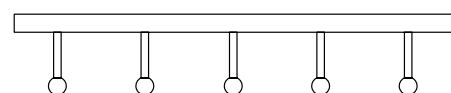

50L x 6,5W x 4H (cm)

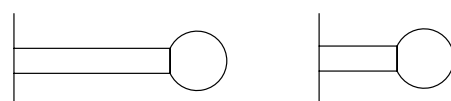

6,5W x 2H (cm)

3,5W x 2H (cm)

Structure



Mirac wall is a multiple wall coat rack made from painted aluminium with chromed brass pegs that can be placed in long rows, ideal for schools and other areas of intensive use.

The individual version of Mirac coat rack, made from chromed brass, can be used as a peg or handle for the doors of bathrooms, dressing rooms, kitchens or any other

place in the home. It has a contemporary, multifunctional design which adapts to any space thanks to its understatement and practicality.



Antoni Arola

Taiga

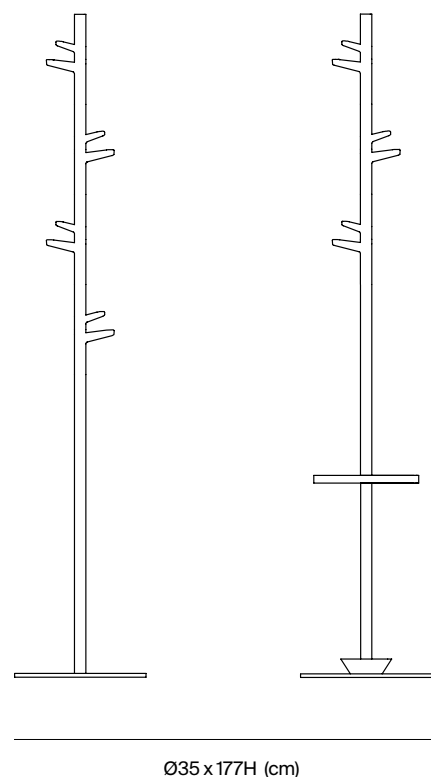

Structure



Taiga coat stand draws inspiration from the organic shapes of Siberia's conifer forest shown in the film Dersu Uzala by the Japanese film director Akira Kurosawa, where the forest is also called Taiga.

The ideal accessory for reception areas and offices. Its structure has eight pegs at differing heights to make it easy to hang garments, bags, etc.



JM Massana & JM Tremoleda

Riga Collection

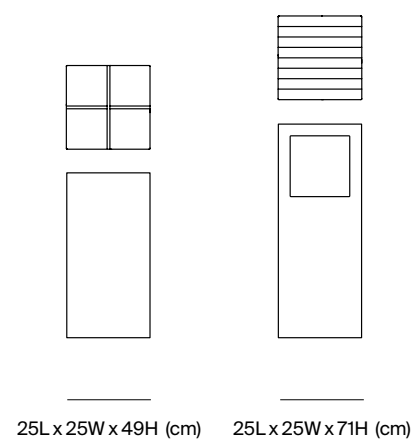
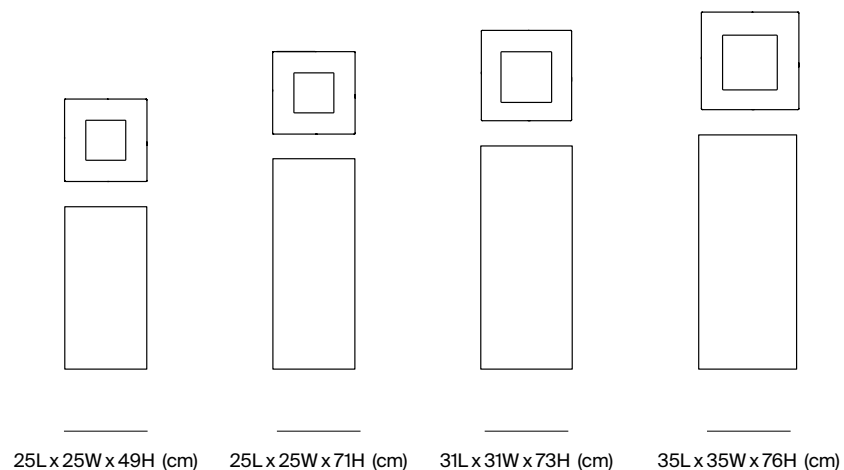

Structure



Top cover



The Riga collection is a minimalist proposal with basic geometrics which manage to be surprising in spite of their apparent simplicity. A formal design that conceals an ingenious, stainless steel corrugated plate; a combination of technology and design resulting from studying the material

and optimising production resources, giving this product the best features and attributes with the minimal possible materials: a sustainable proposal.





Riga Recycling



Structure



Top cover



It has a steel body and an epoxy-painted steel lid, making it hardwearing and practical. It is available in various formats and capacities to meet the functional requirements for recycling.

Riga bins adapt perfectly to contemporary architecture and all kinds of decors in offices, receptions, shops, shopping centres, hotels, cafeterias and bars.



JM Massana & JM Tremoleda

Platea

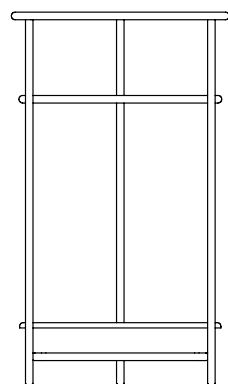

Ø29 x 49H (cm)

Structure



Practical and convenient, the Platea umbrella stand has a large capacity, it's easy to handle and the drip tray can be readily emptied. Thanks to its light appearance, it adapts perfectly to both

classic and contemporary decors and is ideal for locations with a large volume of people such as shops, hotels and reception areas.



Miguel Milá

Tombal

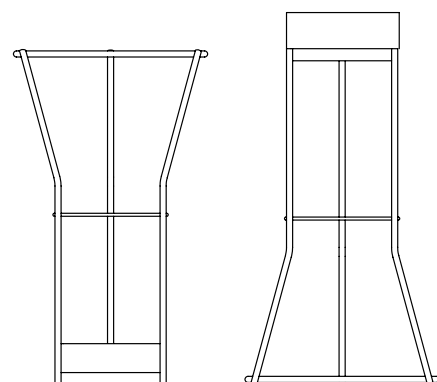

Ø32 x 55H (cm)

Structure



Base



Tombal is an elegant multipurpose product; a practical umbrella stand or an ashtray. Designed in 1990 by Miguel Milá and produced in 2017 by Mobles114. It's a good example that good designs resist the ravages of time. This new production has

maintained the original design and we have only changed the material: stainless steel and ceramic enamel. It's resistant and functional.



Bringing comfort to homes and collective spaces since 1973

Furniture and objects for homes

Mobles114

Furniture for workspaces,
hospitality and public spaces

Mobles114

At Mobles 114, we aim to contribute to improve living spaces to make them more comfortable and welcoming, more beautiful and more livable, whether they are spaces for homes or communities.

Our two catalogs, **Home** and **Contract**, contribute in the same way to sustainability with durable furniture that ages well and can be passed down to future generations.

Shelving

Tria Shelving System – Wall mounted
JM Massana & JM Tremoleda



Tria Shelving System – Floor mounted
JM Massana & JM Tremoleda



Tria Shelving System – Freestanding
JM Massana & JM Tremoleda



Tria Pack Wall
JM Massana & JM Tremoleda



Tria Pack Floor (wall mounted)
JM Massana & JM Tremoleda



Tria Pack Freestanding
JM Massana & JM Tremoleda



Tria Shelf
JM Massana & JM Tremoleda



Seating

Gràcia
JM Massana & JM Tremoleda



Green
Javier Mariscal



Rambla
Martín Azúa



Tube
Eugeni Quitllet



Catalana 1942
German Rodríguez Arias



Danesa
JM Massana & JM Tremoleda



Om
Martín Azúa



Torres Clavé 1934
Josep Torres Clavé



Luco
Martín Azúa



Nuta
Lluís Pau



Nuta Colors
Lluís Pau



Tables

Gràcia
JM Massana & JM Tremoleda

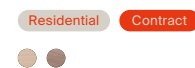

Jujol 1920
Josep Maria Jujol

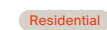

MMS 1963
Miguel Milá



Oxi Bistrot
JM Massana & JM Tremoleda

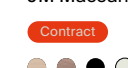

Pey Central
JM Massana & JM Tremoleda

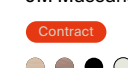

Pey Table System
JM Massana & JM Tremoleda

Residential Contract
○ ● ● ● ● + ○ ●



Rambla
Martín Azúa

Residential Contract
● ○ ● ● ●



Tube
Eugeni Quitllet

Residential Contract
● ○ ● ● ● ●



Tube
Eugeni Quitllet

Residential Contract
● ○ ● ● ● ●



Complements

Bambú
JM Massana & JM Tremoleda

Residential Contract
○ ●



Bambú Wall
JM Massana & JM Tremoleda

Residential
○ ●
● ● ● ● ● ● ● ●

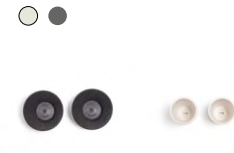

Forc
Lagranja Design

Residential Contract
○ ●



Hulot
Joan Gaspar

Contract
○ ●



Mirac
JM Massana & JM Tremoleda

Residential Contract
● ● ● ○



Mirac Wall
JM Massana & JM Tremoleda

Residential Contract
● ●



Mirac Wall
JM Massana & JM Tremoleda

Residential Contract
○ ●



Ona
Carles Riart i Montse Padrós

Residential Contract
● ● ● ○



Taiga
Antoni Arola

Contract
○ ●



Riga
JM Massana & JM Tremoleda

Contract
● ○ ● ●



Riga Recycling
JM Massana & JM Tremoleda

Contract
● ○ ● + ● ● ● ● ● ● ● ●



Riga
JM Massana & JM Tremoleda

Contract
● ○ ● ●



Riga
JM Massana & JM Tremoleda

Contract
● ○ ● ●



Platea
JM Massana & JM Tremoleda

Contract



Tombal
Miguel Milá

Residential Contract
○ ●



Copenhaguen 1966
André Ricard

Residential
● ●



Tong 1964
André Ricard

Residential



Fil 1991
Álvaro Siza

Residential



Workspaces

- 19 Urbidermis
- 20 Acid House
- 21 Cloudworks Coworking
- 21 Teixidors
- 22 Centre Civic El Mallol
- 23 Marset
- 24 The workmate coworking
- 25 Particular Office
- 26 Mediapro Offices
- 27 Marset
- 27 Corella Offices
- 28 Escuela Técnica Superior de Arquitectura de Granada

Hospitality

- 30 Pork & Tuna
- 30 Veritas
- 31 Tapeo Gracia
- 31 Bar Alma Negra
- 32 Le Bodegon
- 33 Negro
- 34 Casa Fuster
- 35 Vil·la Urània
- 35 Les Punxes
- 35 Cloudworks Coworking
- 36 Bar Mitja Vida
- 36 Bar Dalt de tot
- 37 El Masvell
- 37 L'Olivera Restaurant
- 38 Les Punxes
- 39 Little Spain NY
- 39 Casa Vicens
- 40 Grand Hotel Central

Public Spaces

- 41 El Roure Centre
- 42 Centre Civic El Mallol
- 43 Biblioteca Montserrat Abelló
- 44 Biblioteca Ventura Gassol
- 44 La Ginesta Library
- 45 Les Punxes
- 46 Centre Civic El Mallol
- 47 Biblioteca Ventura Gassol
- 48 Biblioteca Caterina Albert
- 48 El Roure Centre
- 49 Les Punxes
- 50 Escuela Técnica Superior de Arquitectura de Granada
- 51 Centre Cultural Sant Sadurní
- 51 Museu del Disseny de Barcelona

Retail

- 54 Funky Bakers
- 55 Obbio
- 56 Pork & Tuna
- 57 Teixidors

Photography

- Fernando Alda
- Meritxell Arjalaguer
- Martín Azúa
- Lluís Casals
- Estudi Es Pujol de S'Era
- Leo Garcia Méndez
- Adrià Goula
- José Hevia
- François Kollar
- Salva López
- Leo Garcia Méndez
- Ariel Ramírez
- Jordi Sarrà
- Díaz Wichmann
- Pablo Santos
- Jara Varela

Illustrations

- Marta Solserra

Mobles114

Julián Romea 16 / Baixos 2
08006 Barcelona
T. +34 932 600 114
mobles114@mobles114.com
www.mobles114.com

Mobles114