

JUJOL (1920)

by Josep Maria Jujol

Technical specifications (1/2)

m114

Mobles 114

Pau Claris 99 / esc 2 1r 2a

08009 Barcelona

Tel. 34 / 932 600 114

mobles114@mobles114.com

www.mobles114.com



GENERAL DESCRIPTION

Jujol 1920 is a side table that invites being admired as a work of art. A practical, versatile table that adds quality, sobriety and elegance to any interior space.

The Jujol table was designed between 1920 and 1927 by the architect Josep Maria Jujol. This is a reproduction of the table exhibited at the MNAC (National Art Museum of Catalonia). It comes from the house where J M Jujol lived, on the Rambla de Catalunya in Barcelona and, given how it was constructed, we can conclude that it's a prototype.

DIMENSIONS

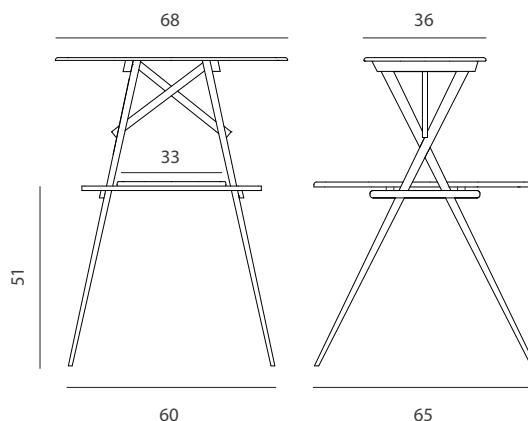

MATERIALS AND FINISHES

This piece is handcrafted.

The table is built with 4 legs, crosspieces and 2 oval table tops, all made of solid oak wood. All pieces are joint together with specific hardware and glue, assuring correct stability and adequate position of the elements. The used glue is of group D-2, following the DIN EN-204 regulation.

The finish of the piece is water-based varnish.

Previously the piece is polished and refined, and the procedure used is the sand and strop method: two undercoats with sanding in-between the two layers, and a topcoat of water-based varnish. We thereby protect the table from the effects of atmospheric agents, also improving physical and chemical resistance.

JUJOL (1920)

by Josep Maria Jujol

Technical specifications (2/2)

m114

Mobles 114

Pau Claris 99 / esc 2 1r 2a

08009 Barcelona

Tel. 34 / 932 600 114

mobles114@mobles114.com

www.mobles114.com

PACKAGING, WEIGHT AND VOLUME

Product weight: 14 kg

Size box: 80x76x95 cm

Volume: 0.58 m³

All packaging is made of double cardboard box, 100% recyclable.