

Technical specifications
(1/3)

Tombal

By Miguel Milá



Mobles114

Technical specifications

(2/3)

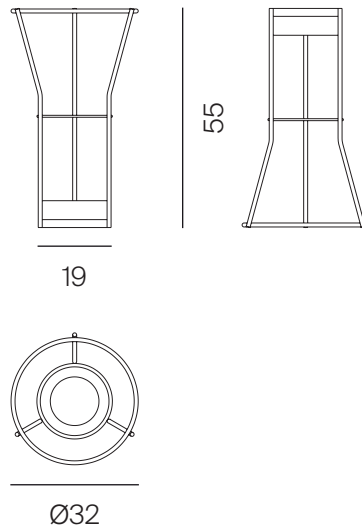

*Metric unit cm

PRODUCT

| Units | Weight |
|-------|--------|
| 1 | 6,5 kg |

PACKAGING

| Units | Weight | Dimensiones | Volumen |
|-------|--------|-------------|---------------------|
| 1 | 6,5 kg | 35x35x65 cm | 0,08 m ³ |

All packaging is double recyclable cardboard.

MATERIALS AND COLORS

Structure



Inox

Container

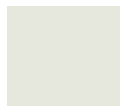

RAL 9002

Technical specifications

(3/3)

MATERIALS AND FINISHES

Both the stainless steel of the structure and the enamelled ceramic of the dish are very resistant to humidity

Structure

Stainless steel structure polished to a high gloss.

Made up of a ring 190 mm in diameter, produced using 20x4 mm rods. This element serves as a base and also to house the enamelled ceramic container. 3 vertical bars 10 mm in diameter, and a ring 320 mm in diameter, also made from a rod, make up the exterior structure of the Tombal.

Another ring is welded 300 mm from the base. This is 190 mm in diameter and made with 5 mm rod, making the product stronger and also helping to support short umbrellas.

All elements are TIG-welded.

Dish

Circular dish made out of naturally coloured enamelled ceramic. The general dimensions are 190 mm in diameter and 70 mm high. This serves as a base for umbrellas or an ashtray, depending on its position.

MAINTENANCE

Clean with a damp cloth with mild soap and water. Rinse and dry with a dry cloth. Avoid using abrasive products.